

**BETTIS**

## D-Series Rack & Pinion Pneumatic Actuators

NAMUR/ISO

Dual Travel Stops

Blowout Proof Pinion



FIVE YEAR Warranty

Three-Point Suspension

Splined Drive Inserts

## Introduction

Bettis® D-Series pneumatic rack and pinion actuators provide its users with reliability and economy in valve automation. Specifically designed for quarter-turn applications, the D-Series is ideal for the on/off or continuous operation of plug, butterfly and ball valves, as well as dampers and other 90° turn devices. The D-Series actuators are compact and lightweight, making them very suitable for installation within areas of tight piping connections.

### Operating Ranges

D-Series actuators produce minimum torque outputs up to 22,379 lb-in (2,528 Nm) for double-acting models and 7,939 lb-in (897 Nm) spring ending torques on spring-return models. D-Series pneumatic actuators are suitable for continuous operation at pressures ranging from 40 to 120 psig (3 to 8 Bar) while exposed to temperatures of -4°F to +175°F (-20°C to +80°C). Optional temperature trims extend the range from -40°F to +250°F (-40°C to +121°C). Consult factory for higher temperatures.

D-Series actuators offer many significant benefits. Among them are:

- **Splined Drive Inserts** – The D-Series blowout-proof shaft is fitted with changeable inserts for universal mounting to a wide variety of valves without the need for brackets or couplings.
- **Corrosion Resistance** – As standard, an exclusive two-component polyurethane epoxy coating, in conjunction with a fully anodized housing and dichromated pistons, provides the D-Series actuators with a highly corrosion resistant surface. Coupled with all 304 SS fasteners, the D-Series provides excellent protection from hostile environments.
- **BettisGuard™** – For the most hostile applications, BettisGuard adds the highest practical level of corrosion protection by impregnating the body and end caps with a ceramic filled fluoropolymer-based

epoxy resin and aluminum pinion gears (BGA). As a further option we can supply stainless steel pinion gears (BGS).

- **Three-Point Suspension** – D-Series pistons feature a unique, three point suspension system. Each piston has three wide, machined load fingers strategically located about the rear circumference of the piston. These load fingers counteract the piston/ rack side loading and prevent the natural tendency of the piston/rack to cock in the actuator bore. To accept and distribute this loading the D-Series is also equipped with a low friction Nylatron body bore bearing. The body bearing, which completely covers the working area of the piston fingers, prevents metal to metal contact and greatly reduces the high point loading often found on other designs with only slim heel bearings. This feature provides for longer, more dependable actuator, piston seal and bearing cycle life.
- **Dual Stroke Adjustment** – Allows stroke adjustment at both outbound and inbound strokes providing for precision alignment of your valves working element (see inset on page 3).
- **Blowout-Proof Pinion** – A unique radiused gearing design protects the pinion gear from blowouts.
- **NAMUR Mounting** – Allows close coupling to NAMUR designated accessories. The pinion gear interface supports a positive, international standard drive for positioners, switches and other accessories.
- **Modular** – The D-Series actuators can easily be converted from double-acting to spring-return configurations as well as many other options.
- **Multiple-Spring Design** – The D-Series has a multiple spring design to facilitate 40 to 120 psig supply air requirements. All springs are “nested” to prevent misalignment and are safely contained by a spring release bolt.

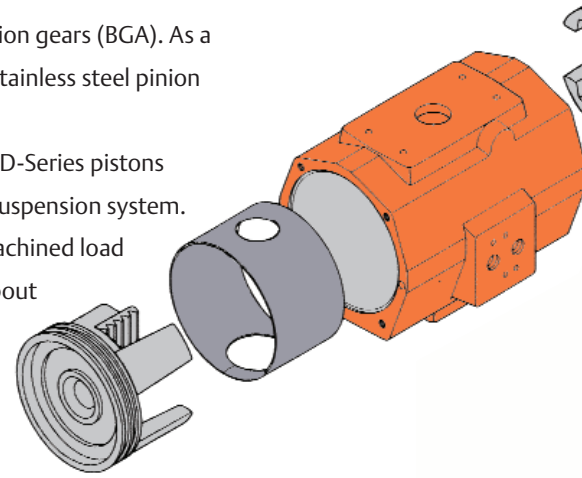

*Two-component polyurethane epoxy coating provides excellent corrosion resistance and chip protection on end caps.*



*Acorn nut and O-ring seal protect bolt threads, and prevent contamination and water ingress*

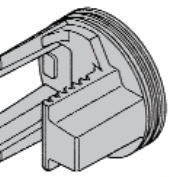

NAMUR accessory interface

Precision stroke adjustment

Low friction piston head and heel bearings

One piece, blowout-proof pinion gear

304 stainless steel fasteners

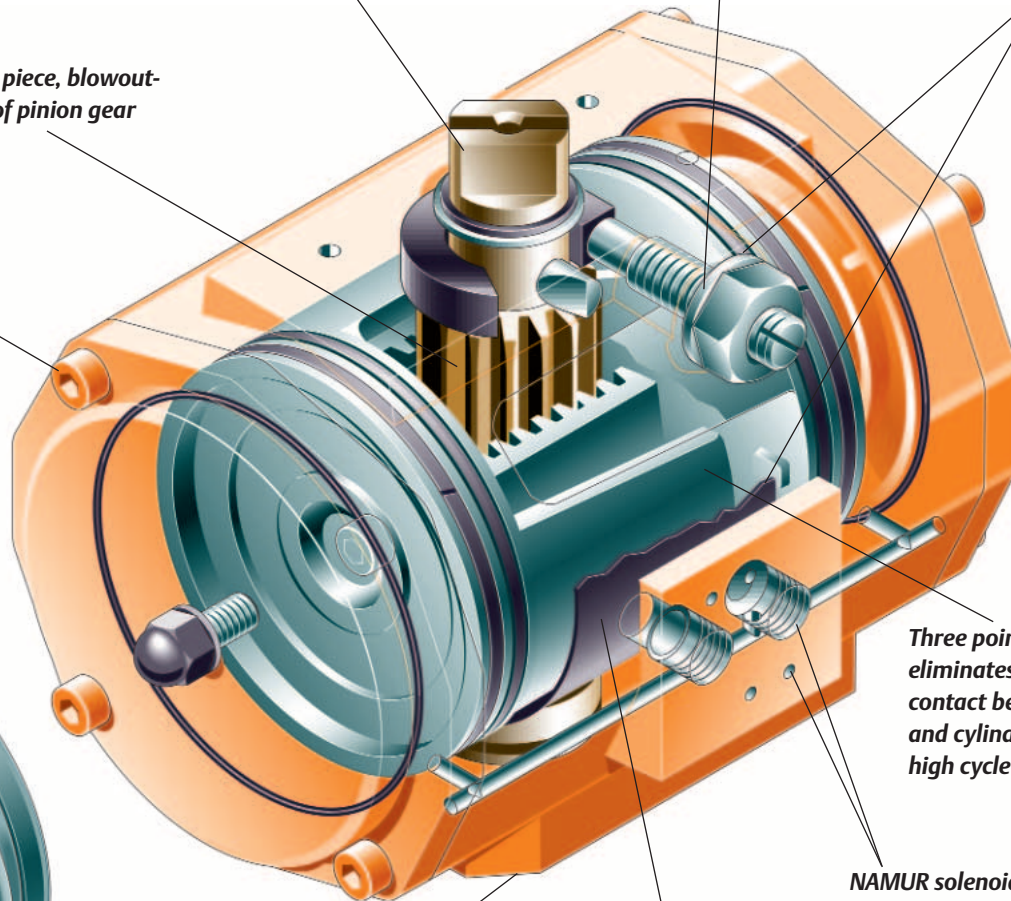

Three point suspension eliminates metal-to-metal contact between pistons and cylinder and promotes high cycle life

NAMUR solenoid direct mounting interface pattern. Note that air ports are also tapped for conventional 1/4" - 18 NPT fittings, except model D0012 utilizes 1/8" - 27 NPT.

ISO/DIN mounting interface for low-profile direct mounting

Nylatron guide band provides 360° piston rack support

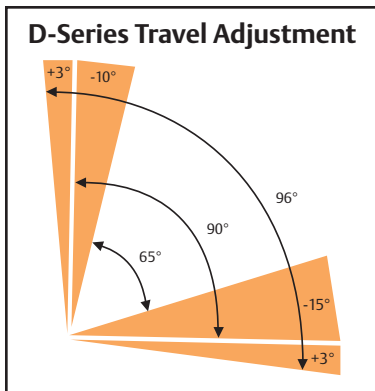

Replaceable drive inserts for universal mounting are easily adapted for custom applications

### Splined Inserts

- Fits into the bottom of the pinion gear shaft to allow universal mounting to a wide range of valve topworks.
- Eliminates special brackets and couplings.
- Available for virtually any valve shaft – square, double D and key drives.



## Materials of Construction

**Body** – Precision cast anodized aluminum alloy.

**Pinion Gear** – Single piece aluminum alloy, hard anodized. Stainless steel optional.

**Pistons** – Cast aluminum alloy with Dichromate corrosion protection.

**End Caps** – Cast aluminum alloy, two part epoxy coated.

**Fasteners** – 304 series stainless steel.

**Seals** – Nitrile is standard. Fluoroelastomer is available for high temperature and silicone for low temperature.

**Springs** – High quality carbon spring steel for maximum life.

**Bearings** – Nylatron standard. Special trims available.

## Sizing Data

D-Series actuators are available in ten spring-return models and ten double-acting models.

## Standards

D-Series actuators are manufactured in accordance with ISO 9001 and also generally comply with the following international standards:

- NAMUR, DVI/DVE 3845
- DIN 3337
- ISO 5211



## Typical Specifications

Operating Pressures	Spring-return and double-acting 40 – 120 psig
Temperature	Standard -4°F to +175°F
	Optional -4°F to +250°F*
	-40°F to +175°F
	*consult factory for higher temperatures
Media	Air dry or lubricated; non-corrosive gas
Rotation	96° total travel adjustment (see inset page 3)

## Torque Ratings

### D-Series Double-Acting Torque (lb.in.) vs. Supply Pressure (psig)

Model	Torque of double-acting actuators (lb.in.)												
	Supply pressure (psi)												
	30	35	40	45	50	55	60	70	75	80	90	100	120
DD0012	44	51	59	66	74	81	90	104	111	119	134	149	179
DD0025	81	95	109	123	137	151	165	193	206	220	248	276	332
DD0040	153	179	205	231	257	283	309	361	387	413	466	518	622
DD0065	233	272	312	352	392	431	471	551	590	630	709	789	948
DD0100	344	402	461	520	578	637	696	813	872	930	1048	1165	1400
DD0200	754	883	1011	1140	1269	1398	1527	1784	1913	2042	2299	2557	3072
DD0350	1310	1534	1757	1981	2205	2428	2652	3100	3323	3547	3994	4442	5337
DD0600	2226	2606	2986	3366	3747	4127	4507	5267	5647	6028	6788	7548	9069
DD0950	3323	3890	4458	5025	5593	6160	6728	7862	8430	8997	10132	11267	13537
DD1600	5493	6431	7369	8307	9245	10183	11121	12998	13936	14874	16750	18626	22379

# Torque Ratings

D-Series Spring-Return Torque (90°: Torque in lb.in.)													
Model	Spring Set	Air Stroke (lb.in.)										Spring Stroke lb.in.	
		Supply Pressure (in psi)											
		40		60		80		100		120		Start	End
DS0012	2	-	-	48	23	80	56	112	87	143	119	64	41
DS0025	1	93	80	152	139	211	197	270	257	329	315	31	20
	2	71	44	129	103	189	162	248	220	306	280	63	39
	3	49	8	107	66	166	126	225	185	284	243	94	58
	4	-	-	85	31	144	90	202	149	261	206	125	78
	5	-	-	-	-	121	54	180	113	239	172	156	98
	6	-	-	-	-	99	18	157	77	216	136	188	117
DS0040	1	175	150	286	260	396	371	506	481	617	591	58	36
	2	133	82	243	193	354	304	464	413	574	524	117	74
	3	90	15	201	126	312	236	422	346	533	457	176	110
	4	-	-	159	58	270	169	380	279	491	390	234	146
	5	-	-	-	-	228	101	338	212	449	322	293	183
	6	-	-	-	-	185	34	296	144	407	255	351	220
DS0065	1	264	224	432	392	600	560	768	728	936	898	93	58
	2	197	117	365	285	533	453	701	622	869	790	186	117
	3	129	10	297	178	466	347	634	515	802	683	279	175
	4	-	-	230	72	398	240	566	408	735	576	372	234
	5	-	-	-	-	331	133	499	301	667	469	465	292
	6	-	-	-	-	264	26	432	195	601	363	558	351
DS0100	1	397	341	645	590	894	838	1143	1087	1392	1337	129	81
	2	304	192	552	441	801	690	1051	939	1299	1188	258	161
	3	211	43	459	293	709	542	958	790	1206	1039	388	242
	4	-	-	366	143	615	392	863	641	1112	889	516	323
	5	-	-	-	-	522	244	771	492	1019	741	646	403
	6	-	-	-	-	429	95	678	344	927	593	775	484
DS0200	1	864	739	1409	1284	1955	1830	2500	2376	3046	2922	289	181
	2	656	406	1201	952	1747	1498	2292	2043	2839	2589	579	361
	3	448	73	994	620	1539	1165	2065	1711	2630	2256	868	543
	4	-	-	786	287	1332	833	1878	1378	2423	1924	1157	723
	5	-	-	-	-	1124	500	1670	1045	2216	1592	1447	904
	6	-	-	-	-	916	167	1462	713	2008	1259	1736	1065
DS0350	1	1483	1273	2431	2221	3379	3169	4327	4117	5276	5065	513	329
	2	1106	684	2053	1632	3001	2580	3949	3528	4897	4477	1025	659
	3	727	96	1675	1044	2623	1991	3571	2939	4519	3887	1537	988
	4	-	-	1297	454	2245	1403	3192	2351	4140	3299	2049	1316
	5	-	-	-	-	1867	813	2815	1762	3762	2710	2561	1645
	6	-	-	-	-	1488	225	2436	1173	3384	2121	3074	1975
DS0600	1	2542	2174	4153	3785	5764	5395	7375	7007	8966	8618	861	541
	2	1920	1183	3531	2794	5142	4405	6753	6017	8364	7628	1723	1083
	3	1298	193	2908	1804	4520	3415	6131	5026	7742	6637	2584	1623
	4	-	-	2287	813	3898	2425	5509	4036	7120	5647	3447	2165
	5	-	-	-	-	3276	1435	4887	3046	6498	4656	4308	2706
	6	-	-	-	-	2654	444	4265	2055	5876	3666	5170	3247
DS0950	1	3810	3250	6215	5655	8620	8060	11025	10464	13430	12869	1282	794
	2	2898	1777	5303	4182	7708	6587	10113	8992	12518	11396	2562	1587
	3	1966	305	4391	2709	6796	5114	9200	7519	11605	9924	3844	2381
	4	-	-	3478	1237	5883	3641	8289	6046	10694	8451	5126	3175
	5	-	-	-	-	4972	2168	7376	4573	9781	6978	6407	3968
	6	-	-	-	-	4059	696	6464	3100	8869	5505	7688	4762
DS1600	1	6286	5397	10262	9373	14237	13349	18213	17325	22188	21299	2096	1323
	2	4765	2988	8741	6964	12716	10939	16692	14914	20668	18890	4193	2646
	3	3245	579	7220	4554	11195	8530	15171	12505	19147	16481	6289	3970
	4	-	-	5699	2145	9675	6120	13650	10095	17625	14071	8385	5293
	5	-	-	-	-	8153	3710	12129	7686	16105	11662	10481	6616
	6	-	-	-	-	6633	1301	10609	5277	14583	9252	12578	7939

# Dimensions

Dim. (Inch)	D-Series									
Model	0012	0025	0040	0065	0100	0200	0350	0600	0950	1600
A (DD)	4.06	6.26	7.09	7.83	8.70	11.14	12.01	15.24	16.69	20.31
B (DS)	4.65	6.77	8.03	9.80	10.51	14.17	15.24	18.78	20.35	25.08
C	2.36	3.15	3.66	4.13	4.65	5.63	7.13	8.66	10.20	11.69
D	0.79	0.79	0.79	0.79	0.79	0.79	0.79	1.18	1.18	1.18
E	0.63	0.63	0.87	0.87	0.87	1.42	1.42	2.17	2.17	2.52
E2	0.91	0.91	1.18	1.18	1.18	1.77	1.77	2.56	2.56	2.95
F	0.39	0.39	0.55	0.55	0.55	0.75	0.75	1.42	1.42	1.42
G	0.47	0.47	0.47	0.47	0.47	0.47	0.47	0.39	0.39	0.39
H	2.36	2.91	3.39	3.86	4.25	5.04	6.81	8.15	9.09	10.43
I	1.30	1.81	2.09	2.26	2.48	2.87	3.71	4.45	4.96	5.59
J	0.83	1.26	1.32	1.54	1.59	1.99	2.85	3.33	4.15	4.74
K	0.50	0.94	1.30	1.30	1.50	2.17	2.17	2.68	2.95	3.74
K1	0.25	-	-	-	-	-	-	-	-	-
L	1.00	-	-	-	-	-	-	-	-	-
L1	2.00	-	-	-	-	-	-	-	-	-
M	0.65	-	-	-	-	-	-	-	-	-
M1	-	1.36	1.36	1.36	1.36	1.97	1.97	2.05	2.52	3.23
M2	-	-	-	-	1.06	1.46	1.46	-	-	-
M3	-	0.669	0.669	0.669	0.787	1.161	1.161	1.161	1.949	2.303
N	0.394	0.04	0.04	0.04	0.06	0.06	0.06	0.06	0.06	0.06
O max.	0.358	0.437	0.556	0.556	0.753	0.871	1.068	1.067	1.424	1.817
O min.	0.354	0.433	0.551	0.551	0.748	0.866	1.063	1.063	1.417	1.811
P	0.476	0.555	0.713	0.713	0.992	1.110	1.425	1.425	1.898	2.370
P1	-	0.555	0.713	0.831	0.909	1.303	1.303	1.437	1.909	2.382
P2	-	-	-	-	0.988	1.264	1.264	-	-	-
R	1.57	2.05	2.56	2.76	2.76	3.54	4.49	4.88	5.12	6.06
R1	1.57	1.97	1.97	1.97	2.36	2.36	2.36	3.54	3.54	4.92
R2	-	-	-	-	-	-	-	-	-	5.20
S	-	2.05	2.56	2.76	2.76	3.54	4.49	4.88	5.59	11.02
S1	-	3.94	3.94	3.94	3.94	3.94	3.94	6.69	6.69	8.27
T	1.57	-	-	-	-	-	-	-	-	9.236
T1	-	3.150	3.150	3.150	3.150	3.150	3.150	5.118	5.118	5.118
U	1.22	-	-	-	-	-	-	-	-	3.827
U1	-	1.181	1.181	1.181	1.181	1.181	1.181	1.181	1.181	1.181
V	1.654	-	1.969	1.969	1.969	2.756	2.756	4.016	4.016	6.496
V1	-	1.969	2.756	2.756	2.756	4.016	4.016	4.921	5.512	-
W	4x10-24 UNC x5.5 deep	-	1/4"- 20x.39	1/4"- 20x.39	1/4"- 20x.39	5/16"- 18x.39	5/16"- 18x.39	3/8"- 16x.63	3/8"- 16x.63	3/4"- 10x1.14
W1	2xM4 x4 deep	1/4"- 20x.39	5/16"- 18x.39	5/16"- 18x.39	5/16"- 18x.39	3/8"- 16x.63	3/8"- 16x.63	1/2"- 13x.79	5/8"- 11x.98	-
W2	4xM4 x4 deep	-	-	-	-	-	-	-	-	5/8"- 11x.98
X	1/8" NPT	-	-	-	-	-	-	-	-	-
Y	M6x.48"	-	-	-	-	-	-	-	-	-

Note: Flange and square drive to ISO 5211. Top and solenoid flange to VDI/VDE 3845 and NAMUR

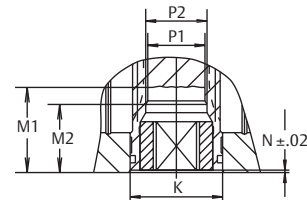
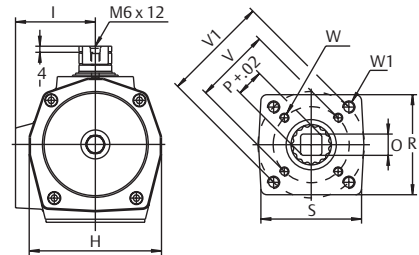
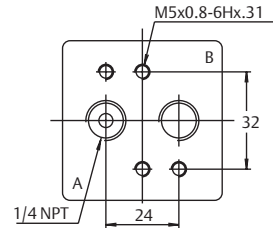
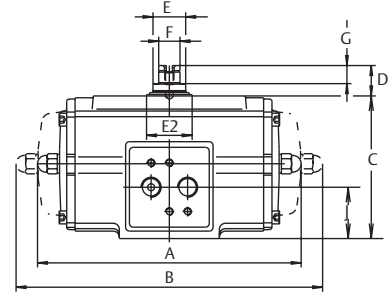
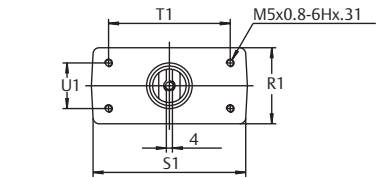

## Model 1600

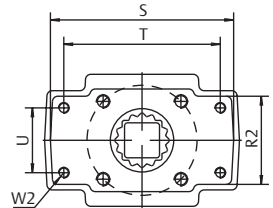

## Model 0012

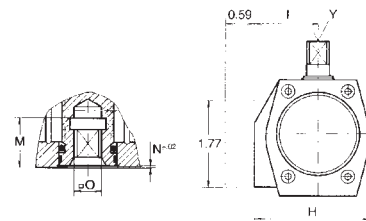
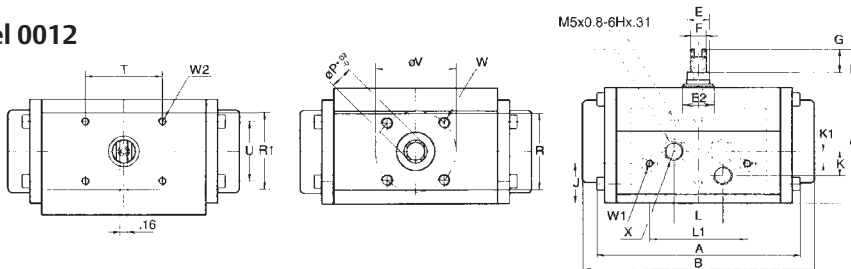

## Technical Data

Model		0012	0025	0040	0065	0100	0200	0350	0600	0950	1600	
Bore	inch	1.8	2.2	2.8	3.1	3.6	4.3	5.7	6.9	7.9	9.1	
Stroke	inch	0.5	0.6	0.7	0.9	1.0	1.5	1.5	1.7	2.0	2.5	
Weight:	(DD) Double-acting	lb.	1.3	2.9	4.0	5.3	6.8	12.8	22.9	42.8	58.2	94.1
	(DS) Spring-return	lb.	1.5	3.7	5.3	7.9	10.1	20.1	37.3	60.8	85.1	145.1
Operating time	sec.	0.4	0.5	0.7	1.1	1.2	2.3	3.6	4.5	5.4	6.9	
Air consumption	port A	stroke	3.1	6.1	9.8	20.1	21.4	49	110	177	287	445
At 1 atm (cu./in.)	port B	stroke	3.7	6.7	13.4	22.0	29.9	61	116	189	299	488

## NAMUR Control Valves and Switches

For actuator control via an electrical or pneumatic signal, Bettis can supply a wide variety of control valves. The direct mount feature to the NAMUR interface eliminates interconnecting tubing and fittings. The universal valve (5/2 or 3/2) can be used for double-acting or spring-return.

The single solenoid control is continuously rated and, in the event of electrical failure, the actuator returns to the clockwise (normal closed or open) position; by mechanical spring in single-acting and air in the case of double-acting.

NAMUR is an international standard which allows direct mounting of control components such as solenoid valves, positioners and mechanical or proximity switches. Note that all D models 0025 through 1600 actuators have air ports which have been drilled and tapped to 1/4" – 18 NPT in the event that traditional imperial tubing or piping is required. D 0012 models (due to size constraints) have as standard 1/8" NPT body air ports with a special non-NAMUR bolt pattern (see drawing). As options, a NAMUR solenoid interface block and NAMUR switch adapter are available for the D0012.

## Control Systems

Bettis D-Series actuators can be equipped with an extensive variety of control systems. Components such as the BettiSwitch II and any NAMUR control component are easily bolted on.



## Accessories

### ■ Gear Operator

Manual Override to open and close the actuator manually. Offered in declutchable (double-acting) or non-declutchable (spring-return) configurations.

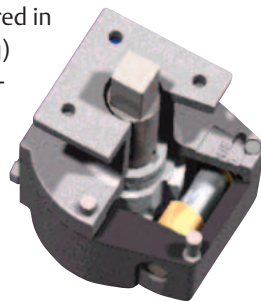

### ■ Breather Block

To prevent contaminants from entering the spring-return actuator.

### ■ Partial Test Stroke Devices (PTSD)

This rugged device allows for a simple, mechanical means of periodic testing for the proper operation of your automation system without upsetting flow processes. Bettis can provide PTSD for testing in either clockwise or counter-clockwise direction with 15–20 degrees of field adjustable rotation and other ranges available. Consult factory with your requirements.

A digital positioner and partial stroke test device provides diagnostics for Emergency Shut Down (ESD) applications. Request detailed information from factory.



## General Control Valve Specifications

Air Pressure	29 – 120 psi	Air Entry	1/4" – 18 NPT
Lubrication	Not needed	Air Flow CV	0.7
Temperature	-13° to +140° F	Assembly	Waterproof to NEMA 4X
Power	AC 2.0W DC 2.5W	<i>Consult factory for details.</i>	

# Bettis D-Series Ordering/Model Designation

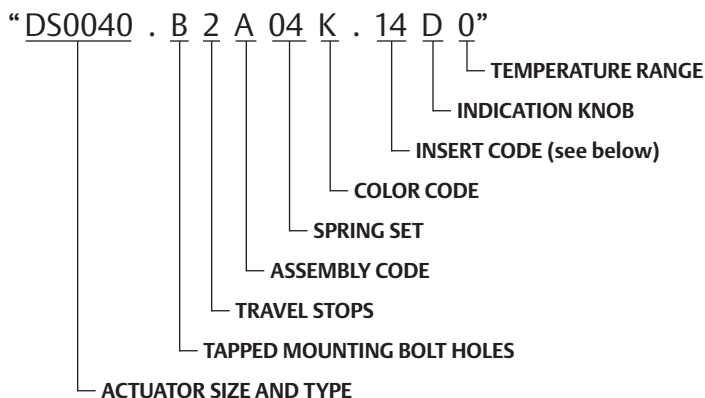

### Actuator Size and Type

DD – D-Series & Double-Acting or  
 DS – D-Series & Spring-Return  
 XXXX – Body size (0012, 0025, 0040, 0065, 0100,  
 0200, 0350, 0600, 0950 or 1600)

### Tapped, Mounting Bolt Holes

B – UNC (Standard Bettis Trim, ISO 5211 with UNC bolt holes on valve mounting side, Metric bolt holes on NAMUR patterns NPT ports)  
 M – All Metric (ISO 5211)  
 D – All DIN (DIN 3337)  
 U – UNC (ISO 5211 with UNC on valve side & NAMUR patterns)

### Travel Stops

2 – Dual Travel Stops (Standard Bettis Trim for all models except for 0012)  
 0 – No Travel Adjustment (Standard Bettis trim only for the 0012. No options)

### Assembly Code

A – Fail-CW (Mounted in line, standard)  
 B – Fail-CW (mounted across line, special order)  
 C – Fail CCW (mounted across line, special order)  
 D – Fail CCW (mounted in line, special order)

### Spring Set Number

00 – No springs (Double-Acting)  
 01, 02, 03, 04, 05 & 06 spring set (Spring-Return only)

### Color Code

K – Bettis orange

### Insert Code – Inner Square

XX – See Options chart (Bettis standard will be the ISO/DIN size)

### Indication Knob

D – Visual Indication (Disk, use only when required with switch for visual indication)  
 K – Visual Indication (Knob, Standard)  
 N – No Visual Indicator

**Temperature Range** – Note: For temperatures outside these ranges contact Bettis

0 – Standard Temperature -4 to 175F (-20 to 80C)  
 1 – High Temperature -4 to 250F (-20 to 121C)  
 2 – Low Temperature -40 to 175F (-40 to 80C)

## Insert Code / Options

Double-Acting (DD) and Spring-Return (DS) Models										
	0012	0025	0040	0065	0100	0200	0350	0600	0950	1600
▲ 00	◆	X	X	X	X	X	X	X	X	X
** 09		X								
10		X	X	X						
11		X*								
12			X	X	X					
14			X*	X*		X	X	X		
16					X	X	X	X		
17					X	X	X	X		
19					X*	X	X	X		
22						X*	X	X	X	
24						X	X	X		
27						X	X*	X*	X	
36									X*	
46										X*
	0012	0025	0040	0065	0100	0200	0350	0600	0950	1600

\* Standard insert for this model, also standard for ISO and UNC

\*\* Insert codes 09 through 46 equals size of female square insert in mm (nominal)

▲ For “00” option, no insert installed

◆ Model not equipped with insert. See drawing on page 6

© 2003, Emerson Process Management. All rights reserved.

The Emerson logo is a trade mark and service mark of Emerson Electric Co.

The contents of this publication are presented for information purposes only, and while effort has been made to ensure their accuracy, they are not to be construed as warranties or guarantees, expressed or implied, regarding the products or services described herein or their use or applicability. All sales are governed by our terms and conditions, which are available on request. We reserve the right to modify or improve the designs or specifications of our products at any time without notice.

### Bettis USA

P.O. Box 508  
 Waller, TX 77484 U.S.A.  
 T 281-727-5300  
 F 281-727-5303  
 Website: www.EmersonProcess.com  
 E-mail: Info.Bettis@EmersonProcess.com

### Bettis Canada Ltd.

4112-91 A Street  
 Edmonton, Alberta T6E 5V2  
 Canada  
 T 780-450-3600  
 F 780-450-1400

