

Micro Trims for Globe and Angle Valve Applications

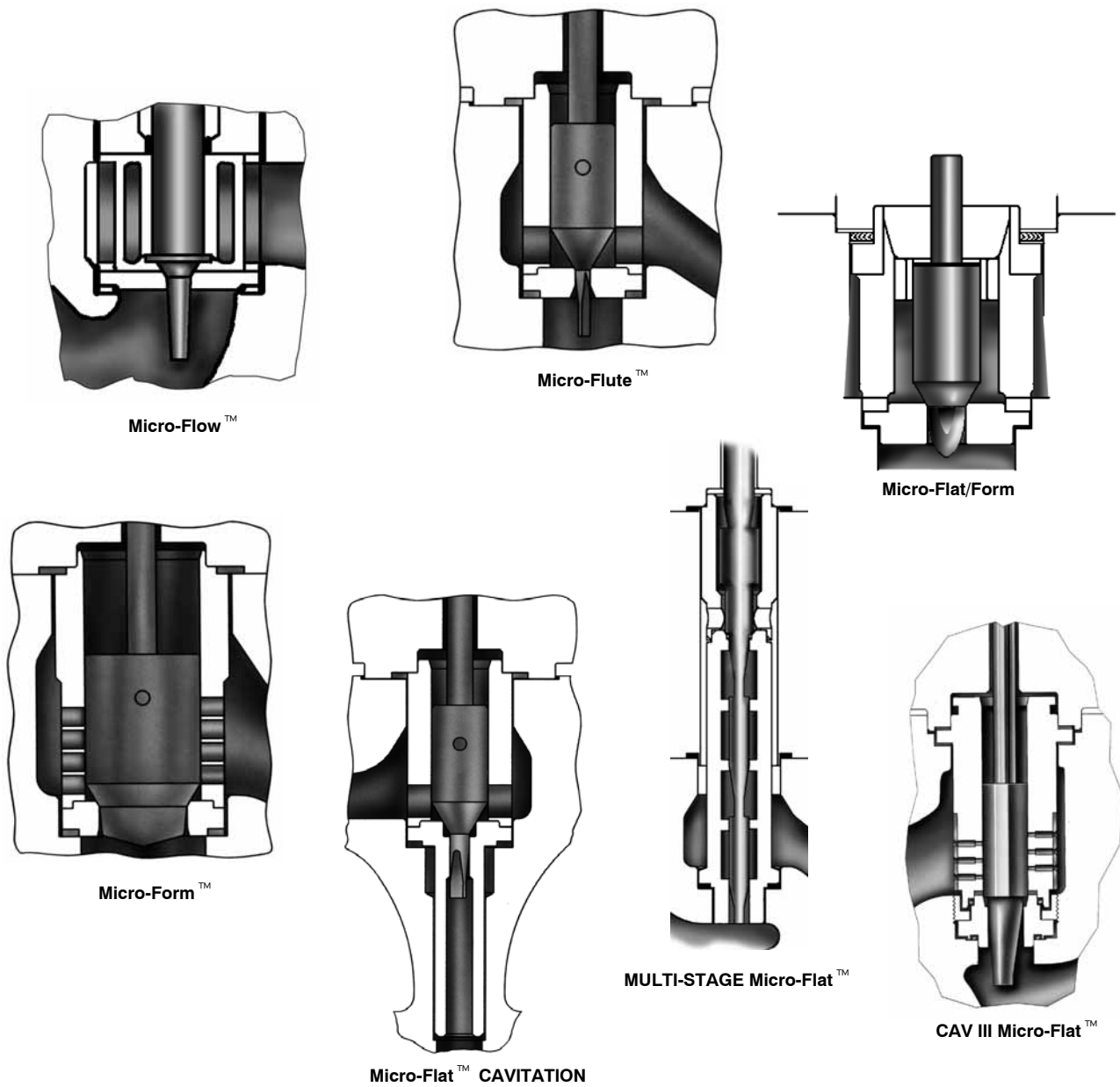

Figure 1. Micro Trims



Micro Trims

Fisher micro trims (figure 1) are used in those applications where the control of low flow rates is a requirement. A variety of micro trims are offered that provide application solutions for standard and severe service conditions. This bulletin lists the various micro trims available and their service capability.

Note

Neither Emerson, Emerson Process Management, nor Fisher assume responsibility for the selection, use, or maintenance of any product. Responsibility for proper selection, use, and maintenance of any Fisher product remains solely with the purchaser and end-user.

Trim Descriptions: An Overview

Fisher micro trims fall into two basic application categories: "Standard Service" and "Severe Service".

Standard Service Micro Trims

These are Plug-Characterized trims. Flow characterization is controlled by the plug.

(A)— Micro-Flow™—Ultra low flow control. Linear flow characteristic. Plug-characterized, port-guided. Gas and liquid applications. See figure 2.

(B)— Micro-Flute™—Low flow control. Bridges the gap between Micro-Flow and Micro-Form trims. Equal Percent flow characteristic.

Plug-characterized, port-guided. Gas and liquid applications. See figure 3.

(C)— Micro-Form™—Equal percent, contoured plug used in a variety of valve designs. See figure 4.

(D)— Micro-Flat/Form—General service gas or liquid applications where high rangeability (>200:1) is required. See figure 5.

Severe Service Micro Trims

Cavitation Isolation Trim—controls where cavitation occurs in the valve to minimize trim damage. Does not prevent formation of cavitation.

Cavitation Elimination Trim—trim design eliminates the effects of cavitation.

(E)— Micro-Flat™ Cavitation Trim—Cavitation isolation trim. Low C_v , is intended for use in angle valves only. Not recommended for use in globe valves. See figure 6.

(F)— Multi-Stage Micro-Flat—Plug/Cage design with a series of flats on a common stem. High ΔP 's and C_v 's down to approximately 0.01. This is a cavitation elimination trim for use on liquids. Not intended for gas service. See figure 7.

(G)— CAV III Micro-Flat—Cage-guided cavitation elimination trim. This trim is a CAV III multi-stage trim with the addition of a Micro-Flat style plug to provide staged performance at low flows. Allows CAV III staged cavitation control as low as $C_v = 0.05$. See figure 8.

Table 1. Micro Trim Application⁽¹⁾

Trim	Trim Name	Valve Type	Valve Size Range	C _v Availability ^(2, 3)
(A)	Micro-Flow	EZ HP CP D	0.5, 0.75, 1, 1.5, and 2-inch 1-inch 1-inch 1-inch	0.015 – 0.181 0.00365 - 0.294 0.00365 - 0.294 0.00365 - 0.294
(B)	Micro-Flute	EZ HPS D	0.5, 0.75, 1, 1.5, and 2-inch 1-inch 1-inch	0.0385 - 1.07 0.039 - 4.21 0.0385 - 1.07
(C)	Micro-Form ⁽⁴⁾	easy-e® HPS EH CP ⁽³⁾ D	1, 1.5, and 2-inch 1 and 2-inch 2-inch 0.5, 0.75, 1, 2, 3, and 4-inch 1 and 2-inch	0.075 - 10.2 0.072 - 52.2 0.062 - 50.1 0.153 - 175 0.070 - 34.5
(D)	Micro-Flat/Form	easy-e HPS EH D	1, 1.5, and 2-inch 1 and 2-inch 2-inch 1 and 2-inch	0.02 - 28.9 0.02 - 28.9 0.02 - 28.9 0.02 - 8.8
(E)	Micro-Flat Cavitation	EAS HPAS DA	1-inch 1 and 2-inch 1-inch	0.01 - 3.4 0.01 - 7.8 0.01 - 3.4
(F)	Multi-Stage Micro-Flat	ES HPS EHS	1, 1.5, and 2 1 and 2-inch 2-inch	0.01 - 1.4 0.01 - 1.4 0.01 - 1.4
(G)	CAV III Micro-Flat	ES HPS EHS	1, 1.5, and 2 1 and 2-inch 2-inch	0.05 - 4.9 0.05 - 5.5 0.05 - 5.5

1. Configurations shown are standard. Other configurations are available. Consult your Fisher sales office.
 2. The trim selected may have the minimum or the maximum C_v, as shown below, but usually not both. Refer to Catalog 12 for further detail on flow coefficients for the various valve types.
 3. Consult your Fisher sales office for C_v requirements and availability, dependent on valve size, design, etc.
 4. Referred to as equal percent trim for Design CP valves.

Detailed Trim Description

Standard Service Trims

(A)—Micro-Flow™ Trim

Micro-Flow trim (figure 2) provides linear ultra low flow control in gas and liquid applications. Typical application for this trim is flow up, 0.1875 inch port diameter, and 0.75 inch travel.

This is a very rugged, tough trim and therefore available in limited materials, such as stellite. Micro-Flow trim construction consists of a very tightly controlled angle milled on a flat. This low angle flat provides the required flow control.

This unbalanced trim, with a linear plug characteristic, is available in most valve styles, including easy-e, Designs D, HP, and CP.

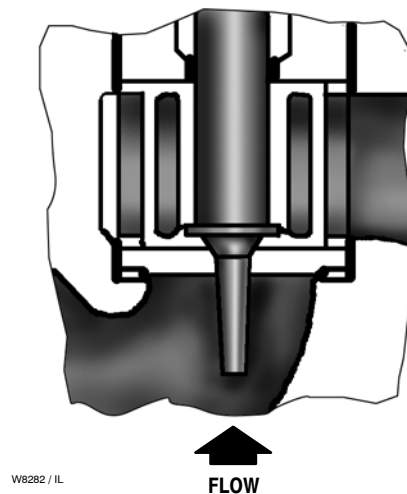

Figure 2. Micro-Flow Trim

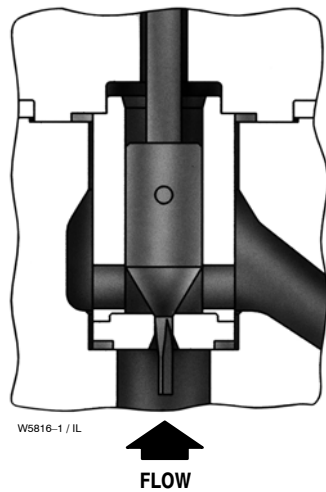

Figure 3. Micro-Flute Trim

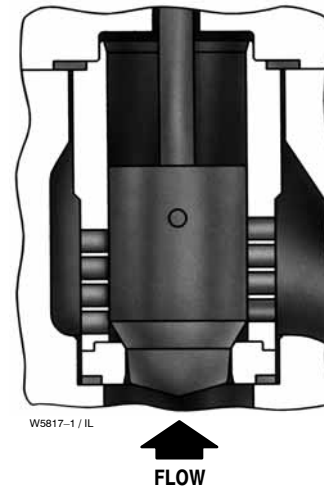

Figure 4. Micro-Form Valve Plug

(B)—Micro-Flute™ Trim

Micro-Flute trim (figure 3) is for low flow equal percent control applications and fills the niche between Micro-Flow applications and Micro-Form applications. Standard trim material is stellite and 440C.

Micro-Flute trim is port guided. The plug tip rides in the seat ring, which is the area where energy is dissipated. Typical applications are port diameters as small as 0.25 inch and flow up (with some flow down applications).

(C)—Micro-Form™ Trim

Micro-Form trim (figure 4) is a contoured plug, equal percent trim for low flow applications. This plug characterized trim is available in 0.25 inch and larger ports. Micro-Form trim is used in flow up applications and not recommended for flow down use.

Depending on valve type, this trim is either cage-guided, stem-guided, or post-guided. Micro-Form trim is widely used in Designs EZ and CP, as well as small size Designs EH and HP control valves.

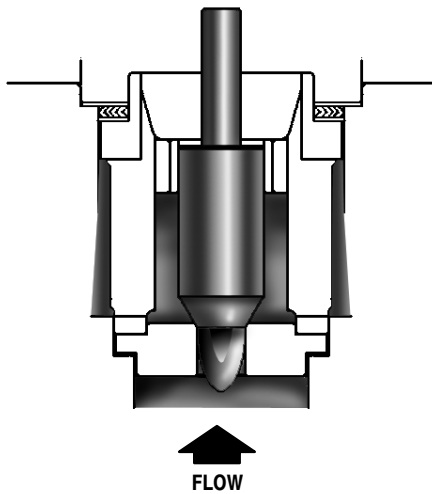

Figure 5. Micro-Flat/Form Trim

(D)—Micro-Flat/Form Trim

Micro-Flat/Form trim (figure 5) is a special plug design for flow up service only. Using features from both Micro-Flat and Micro-Flow trims, this trim is designed for high rangeability flow service.

Micro-Flat/Form trim initially operates as Micro-Flat, where it is tightly toleranced to optimize low flow control. Further up in the stroke the trim transitions to a Micro-Form style plug contour. This provides improved C_v coefficient control. Rangeability is possible in excess of 200 to 1. This trim is available in Micro-Form materials. When choosing materials, be aware of the sliding contact at low lifts.

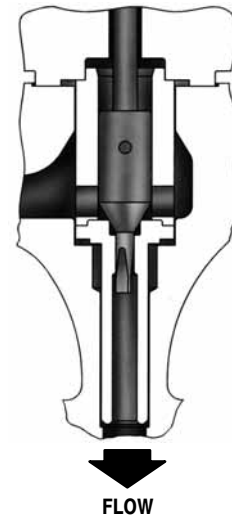

Figure 6. Micro-Flat Cavitation Trim

Severe Service Trims

(E)—Micro-Flat™ Cavitation Trim

Micro-Flat Cavitation trim (figure 6) is designed for flow down applications only. This trim design does not eliminate cavitation but controls where cavitation occurs to minimize trim damage.

Micro-Flat Cavitation trim features a protected seat design to maximize seat life in cavitating environments. This trim is available in 0.25 inch and larger port diameters with a minimum C_v of 0.01. Recommended maximum pressure drop is 1000 psi. Above this, shortened trim life will result.

This plug-characterized, port-guided trim is available in hardened materials only, such as stellite and 440C. These materials are needed to provide wear resistance between the plug and seat ring, where cavitation and vibration problems exist.

Micro-Flat Cavitation trim is recommended for angle valve applications. In special cases use with a globe valve and flash basket is possible. Consult your Fisher sales office for additional information.

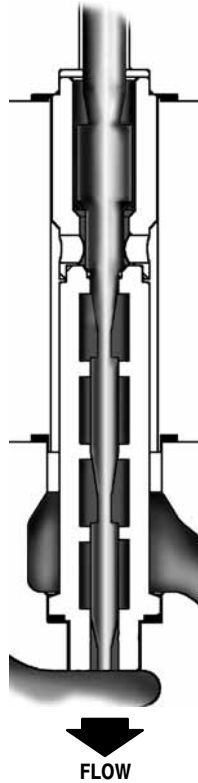

38B3301/A
W8285 / IL

Figure 7. Multi-Stage Micro-Flat Trim

(F)—Multi-Stage Micro-Flat Trim

Multi-Stage Micro-Flat trim (figure 7) is a plug-characterized design with a series of flats on a common stem to provide staged cavitation control. Flow direction is typically flow down, but flow up use is possible in special cases. Consult your Fisher sales office for additional information.

This trim is used to eliminate cavitation. Features include a protected seat design and pressure drops in excess of 4000 psi. To maximize seat life in cavitating environments, staged flow control as low as $C_v = 0.01$ is possible. This trim must be used with hardened materials, such as stellite and 440C.

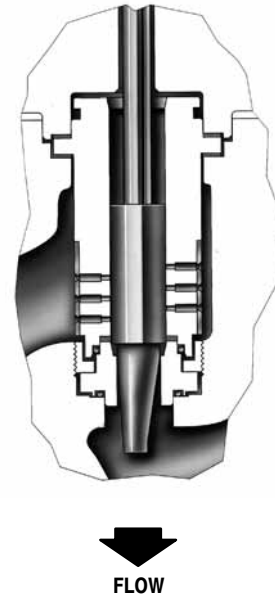

W5624LG

Figure 8. CAV III Micro-Flat Trim

(G)—CAV III Micro-Flat Trim

CAV III Micro-Flat trim (figure 8) is a cavitation elimination trim. Designed as an enhancement to extend the low flow capability of Cavitrol® III, this is a cage-guided trim with the addition of a Micro-Flat plug.

This trim incorporates a protected seat design and the trim is able to provide a staged cavitation control down to approximately $0.05 C_v$. Use of this trim below $0.05 C_v$ is not recommended. This trim is available in Cavitrol III standard materials.

Cavitrol, Micro-Flow, Micro-Flute, Micro-Form, Micro-Flat, and Fisher are marks owned by Fisher Controls International LLC, a member of the Emerson Process Management business division of Emerson Electric Co. The Emerson logo is a trademark and service mark of Emerson Electric Co. All other marks are the property of their respective owners.

The contents of this publication are presented for informational purposes only, and while every effort has been made to ensure their accuracy, they are not to be construed as warranties or guarantees, express or implied, regarding the products or services described herein or their use or applicability. We reserve the right to modify or improve the designs or specifications of such products at any time without notice.

Neither Emerson, Emerson Process Management, nor Fisher assume responsibility for the selection, use or maintenance of any product. Responsibility for proper selection, use and maintenance of any Fisher product remains solely with the purchaser and end-user.

Emerson Process Management

Fisher

Marshalltown, Iowa 50158 USA

Cernay 68700 France

Sao Paulo 05424 Brazil

Singapore 128461

www.Fisher.com

