



High Pressure Modulating Pilot Control Valve

Series 3800

Now with
Set Pressures
to 2220 psig

Reduce product loss and fugitive emissions with the higher-pressure PCM non-flowing modulating pilot control valve.

Available in standard model with set pressures from 15 to 1500 psig, the new model extends the set pressure range to 2220 psig.

Both units open in proportion to the overpressure to minimize emissions and product loss as well as to reduce noise. Both share these additional benefits: reduction of water hammer that can cause undue stress in piping systems; set pressure unaffected by constant or variable backpressure; direct interchangeability with snap-acting pilot control in the field for both cost and time savings.



*Patents
5,950,657 and
6,209,577*

PCM Non-flowing Modulating Pilot Control Features:

- Sizes 1" X 2" through 8" X 10"
- Typical blowdown of 3-6%
- All stainless steel construction
- ASME NB Certified for air, gas, vapor and liquid service
- Convertible to NACE service



Farris Engineering

Division of Curtiss-Wright Flow Control Corporation

Bill of Materials



Built in conformance to the ASME Code Section VIII for Air, Gas, Vapor, and Liquid Service.

Item No.	Part Name	Materials
1	Body	SA-351 GR. CF8M
2	Bonnet	SA-351 GR. CF8M
3	Guide, High Pressure	316 St. St.
4	Piston	316 St. St.
5	Spring Button	316 St. St.
6	Spring Adjusting Screw	316 St. St.
7	Cap	316 St. St.
8	Piston Seal	Viton®
9	Backup Ring	Teflon®
10	Inlet Seat	316 St. St.
11	Body Seal	Viton (Note 1)
12	Spool Cap	316 St. St.
13	Spool Cap Seal	Viton (Note 1)
14	Bonnet Cap Screw	Series 300 St. St.
15	Spool	316 St. St.
16	Spool Seal	Viton (Note 1)
17	Seat Seal	Viton (Note 1)
18	Spool Return Spring	St. St. (Note 1)
19	Lower Return Spring	St. St. (Note 1)
20	Spring	St. St.
21	Jam Nut	Series 300 St. St.
22	Filter	Series 300 St. St.
23	Filter Seal	Viton (Note 1)
24	Filter Housing	316 St. St.
25	Bug Vent (not shown)	Commercial Grade
26	Wire Seal	St. St. Wire/Lead Seal
27	Name Plate (not shown)	St. St.

1. For NACE service (S7 trim), substitute ethylene propylene soft goods and Inconel® X for return springs.

Viton is a registered trademark of DuPont Dow Elastomers.
Teflon is a registered trademark of the DuPont Company.
Inconel is a registered trademark of Special Metals Corporation.

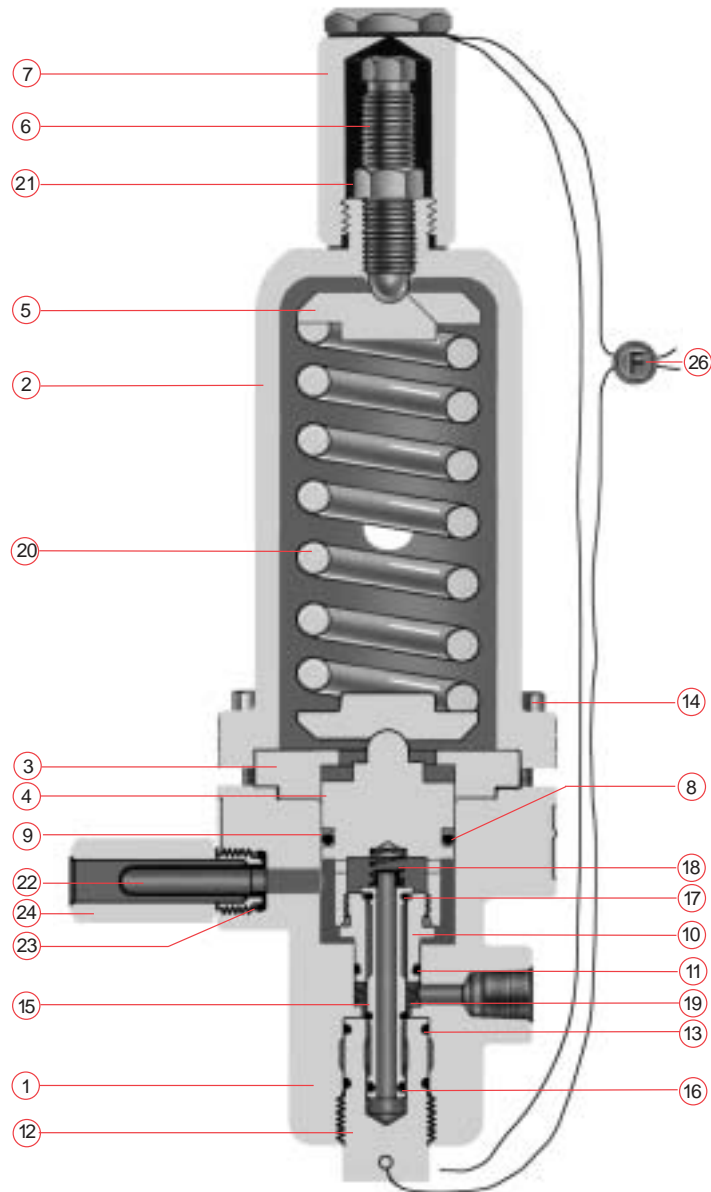

10195 Brecksville Road, Brecksville, OH 44141 USA • Telephone: 440/838-7690 • Fax: 440/838-7699 • www.cwfc.com

Facilities: Brecksville, OH USA, E. Farmingdale, NY USA, Brantford, Ontario Canada, Bridport, UK

Offices: For a listing of our global sales network, visit our website at www.cwfc.com.

While this information is presented in good faith and believed to be accurate, Farris Engineering does not guarantee satisfactory results from reliance upon such information. Nothing contained herein is to be construed as a warranty or guarantee, expressed or implied, regarding the performance, merchantability, fitness or any other matter with respect to the products, nor as a recommendation to use any product or process in conflict with any patent. Farris Engineering reserves the right, without notice, to alter or improve the designs or specifications of the products described herein.