

# Modulating Pilot Control Valve

Series 3800

Now with  
Liquid  
Service

## Reduce product loss and fugitive emissions with the PCM non-flowing modulating pilot control valve from Farris Engineering.

The PCM Modulating Pilot Control offers a variety of features and benefits. It opens in proportion to the overpressure to minimize fugitive emissions and product loss as well as to reduce noise. The PCM also reduces shock loads on vessels and piping due to valve actuation. Its set pressure is not affected by constant or variable back pressure. In addition, the PCM Modulating Pilot Control can be directly interchanged with a PCF3 or PCL snap-acting pilot control in the field for both cost and time savings.



### PCM Non-flowing Modulating Pilot Control:

- Sizes 1" X 2" through 8" X 10"
- Set pressures from 15-1500 psig
- Typical blowdown of 3-6%
- All stainless steel construction
- ASME NB Certified for air, gas, vapor and liquid service
- Convertible to NACE service



**Farris Engineering**

Division of Curtiss-Wright Flow Control Corporation



Built in conformance to the ASME Code Section VIII for Air, Gas, Vapor, and Liquid Service.

**Modulating, Non-Flowing:** the PCM modulating pilot control is modulating and non-flowing, minimizing the flow of line media through the main valve for reduced fugitive emissions and longer valve life.

**Full 316 Stainless Steel Construction:** resists corrosion and extends the operation and versatility of the PCM valves.

**Blowdown:** typically 3 to 6% dependent on service fluid. The PCM is a fixed blowdown pilot control with no external adjustment.

**Viton® Seats and Seals:** have a wide spectrum of chemical compatibility and temperature range to meet most applications and enhance valve life. Buna-N and ethylene propylene soft goods are optional and extend temperature ranges from -65° F to 450° F. Contact the Farris Factory for more information on other construction materials.

**Set Pressure Set at Pilot Control:** in-line service and setting adjustments are done quickly and easily without main valve intrusion. Subsequent reduction in product loss and fugitive emissions adds to the system's profitability.

**Field Test Capable:** using a field test connection allows cycling the pilot valve without interrupting system protection or removing the valve from the line. Field testing verifies system integrity in accordance with the ASME Code.

**Remote Sensing Capable:** the pilot sensing line can be installed directly into the pressure vessel when the main valve is placed in the most ergonomic position. The relief valve, while remote from the vessel, operates on the actual system pressure regardless of inlet piping losses.

**Convertible to NACE Service:** with the high quality of construction materials, conversion to NACE service is simple.

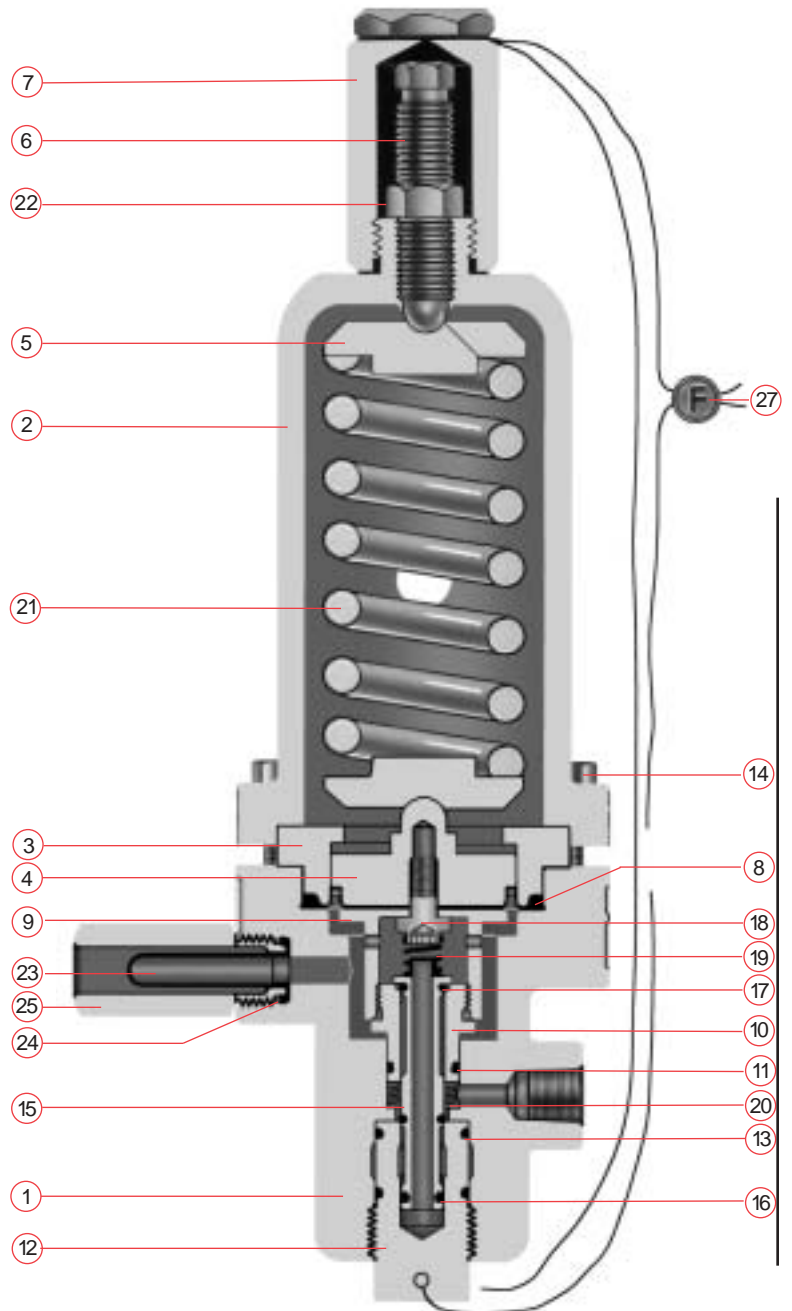



# Bill of Materials

Item No.	Part Name	Materials
1	Body	SA-351 GR. CF8M
2	Bonnet	SA-351 GR. CF8M
3	Guide	316 St. St.
4	Diaphragm Piston	316 St. St.
5	Spring Button	316 St. St.
6	Spring Adjusting Screw	316 St. St.
7	Cap	316 St. St.
8	Diaphragm	Fluorocarbon/Fiber Reinforced (Note 1)
9	Diaphragm Retainer	316 St. St.
10	Inlet Seat	316 St. St.
11	Body Seal	Viton (Note 1)
12	Spool Cap	316 St. St.
13	Spool Cap Seal	Viton (Note 1)
14	Bonnet Cap Screw	Series 300 St. St.
15	Spool	316 St. St.
16	Spool Seal	Viton (Note 1)
17	Seat Seal	Viton (Note 1)
18	Retainer Screw	316 St. St.
19	Spool Return Spring	St. St. (Note 1)
20	Lower Return Spring	St. St. (Note 1)
21	Spring	St. St.
22	Jam Nut	Series 300 St. St.
23	Filter	Series 300 St. St.
24	Filter Seal	Viton (Note 1)
25	Filter Housing	316 St. St.
26	Bug Vent (not shown)	Commercial Grade
27	Wire Seal	St. St. Wire/Lead Seal
28	Name Plate (not shown)	St. St.

1. For NACE service (S7 trim), substitute ethylene propylene soft goods and Inconel® X for return springs. Inconel is a registered trademark of Special Metals Corporation.

# Principles of Operation



**Closed Valve Position:** the pressure pickup allows system pressure from the inlet of the main valve through to the pilot control inlet port and into the dome of the main valve. The pressure area of the piston in the dome of the main valve is greater than the nozzle seat area. The greater the system pressure, the greater the seating force holding the main valve piston on the nozzle seat. As system pressure increases and approaches set pressure, the force acting upward on the pilot control diaphragm/piston increases, overcoming the spring force of the pilot control causing the inlet seat to lift and seal against the floating spool. Pressure is trapped in the dome because of the inlet seal and the outlet seal being closed.

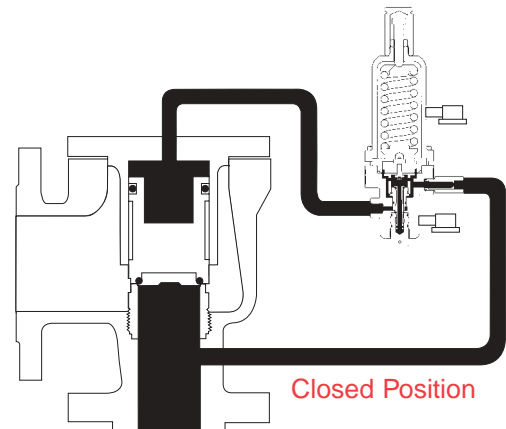

**Modulating Cycle:** any further incremental increase or decrease in system pressure near set pressure raises or lowers both the inlet seat and spool causing the outlet seat seal to crack open or close. This allows a partial venting of dome pressure at increase in system pressure or re-pressurizing of the dome when the inlet seat opens at decrease in system pressure.

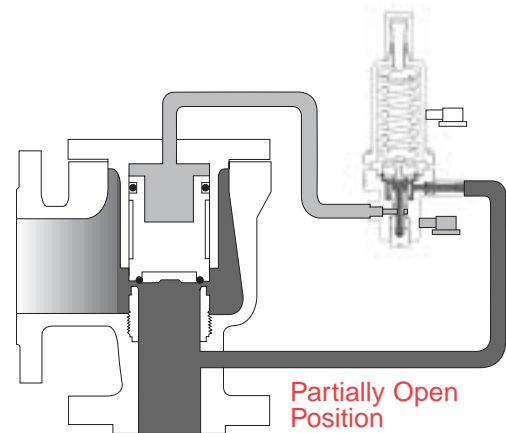

**Relieving Cycle:** as the system pressure increases to set point, the modulating pilot control further reduces the pressure in the main valve dome by the opening of the outlet seal of the pilot control. The decrease in dome pressure caused by increasing system pressure reduces the seating force to zero and opens the main valve seat to allow flow. The modulating cycle occurs when the flow requirement is below the maximum rated flow of the valve. Maximum rated flow is achieved on or before 10% overpressure.

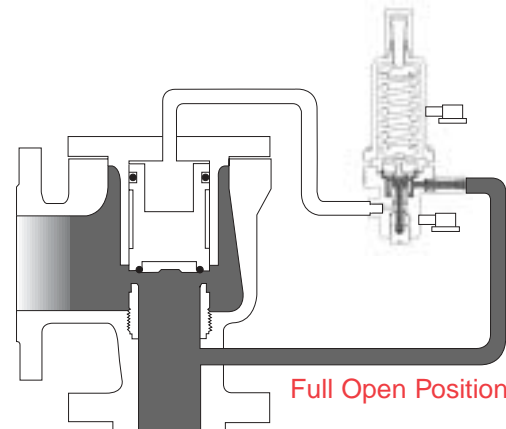

**Re-Closing Cycle:** as the system pressure is decreased below set pressure, the spring force in the modulating pilot control overcomes the system pressure acting on the diaphragm/piston assembly and re-closes the outlet seat. The inlet seat then opens and allows system pressure back into the main valve dome, reseating the main valve.



10195 Brecksville Road, Brecksville, OH 44141 USA • Telephone: 440/838-7690 • Fax: 440/838-7699 • [www.cwfc.com](http://www.cwfc.com)

**Facilities:** Brecksville, OH USA, E. Farmingdale, NY USA, Brantford, Ontario Canada, Bridport, UK

**Offices:** worldwide. For a listing of our global sales network, visit our website at [www.cwfc.com](http://www.cwfc.com).

While this information is presented in good faith and believed to be accurate, Farris Engineering does not guarantee satisfactory results from reliance upon such information. Nothing contained herein is to be construed as a warranty or guarantee, expressed or implied, regarding the performance, merchantability, fitness or any other matter with respect to the products, nor as a recommendation to use any product or process in conflict with any patent. Farris Engineering reserves the right, without notice, to alter or improve the designs or specifications of the products described herein.

©Farris Engineering 2001  
Printed in USA  
R1 5M 7/01