

Series 1896M

Pressure Relief Valves for Air,
Steam, Vapor & Liquid Service

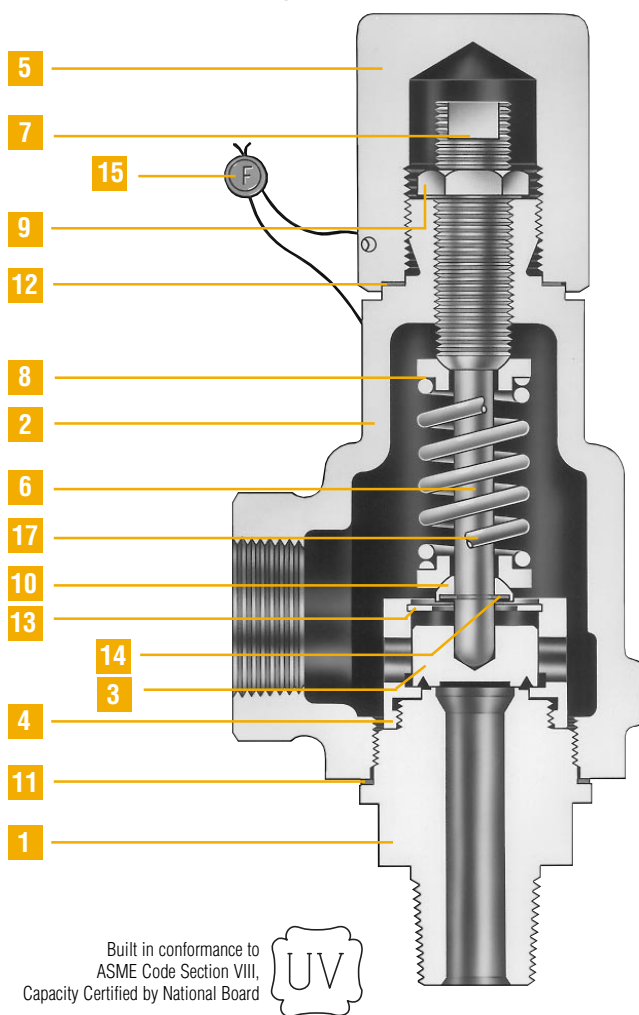

- Built in conformance to ASME Code Section VIII for Air, Steam, and Liquid Service.
- Set pressures to 300 psig.
- Brass body and trim.
- Bronze bonnet and cap.



Bill of Materials		
Item No.	Part Name	Material
1	Body	ASTM B16 H.H. Brass
2	Bonnet	SB-62 Bronze
3	Disc	ASTM B16 H.H. Brass
4	Guide	Brass
5	Cap, Plain Screwed	Brass
6	Stem	St. St.
7	Spring Adj. Screw	Brass
8	Spring Button	St. St.
9	Jam Nut	Brass
10	Stem Shoulder	St. St.
11	Body Gasket	316 St. St.
12	Cap Gasket	316 St. St.
13	Lift Stop Ring	St. St.
14	Retaining Ring-Stem Shoulder	St. St.
15	Wire Seal	Stainless Steel Wire/Lead Seal
16	Nameplate (not shown)	St. St.
17	Spring	316 St. St.

- General Notes:**
1. 1896M is for use on air, gas, steam or vapor service. 1896ML for use on liquid service. For test gag, add W/TG.
 2. Test lever required for air, steam, and hot water (above 140°F) service. For packed lever, add PKD. Example: 1896M-PKD.
 3. Maximum set pressure for steam service is 240 psig (saturation temperature of 400°F).

Selection Table							
Type Number	Valve Size Inlet x Outlet	Connections		Maximum Set Pressure, psig -400°F to 400°F	Maximum Back Pressure psig at 100°F	Materials	
		Inlet	Outlet			Body/Bonnet	Spring
1896M	1/2 x 3/4 & 3/4 x 3/4	Male NPT	Female NPT	300	50	Brass/Bronze	316 St. St.
1896ML	1/2 x 3/4 & 3/4 x 3/4	Male NPT	Female NPT	300	50	Brass/Bronze	316 St. St.

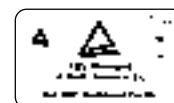



Capacity Tables: ASME PRESSURE VESSEL CODE (UV)

AIR 10% OVERPRESSURE Capacities in Standard Cubic Feet Per Minute at 60° F	
Set Pressure (psig)	Air Capacity
15	51
20	59
30	74
40	91
50	108
60	125
70	143
80	160
90	177
100	194
120	228
140	262
160	296
180	331
200	365
220	399
240	433
260	468
280	502
300	536

STEAM 10% OVERPRESSURE Capacities in Lbs. Per Hour at Saturation Temperature	
Set Pressure (psig)	Steam Capacity
15	143
20	165
30	208
40	256
50	304
60	353
70	401
80	449
90	497
100	545
120	641
140	737
160	833
180	929
200	1025
220	1121
240	1217

WATER 10% OVERPRESSURE Capacities in U.S. Gallons Per Minute at 70° F (See Note 2)	
Set Pressure (psig)	Water Capacity
15	9.4
20	10.6
30	12.7
40	14.7
50	16.4
60	17.9
70	19.4
80	20.7
90	22.0
100	23.2
120	25.4
140	27.4
160	29.3
180	31.1
200	32.8
220	34.4
240	35.9
260	37.4
280	38.8
300	40.1

Notes: 1. Capacities at 30 psig and below are based on 3 psi overpressure. 2. To determine water capacity at 25% overpressure, multiply the capacity at 10% by 1.066.
3. Maximum set pressure for steam service is 240 psig (saturation temperature of 400°F).

Effective Orifice Areas (Sq. In.)		
Inlet Size	Liquids Only	Vapors, Gases & Steam
1/2 or 3/4	0.077	0.089

Notes: 1. For sizing purposes, the coefficient of discharge K_d is 0.953 for air, gas and vapor.
2. For liquid service, use the ASME liquid equation with a coefficient of discharge K_d equal to 0.755.

Dimensions & Weights (MNPT x FNPT)						
	Size	A		B	C	Approx. Weight (lbs.)
		Plain Cap	Packed Lever			
1896M	1/2 x 3/4	6 5/16	7 1/2	1 9/16	2 7/16	3
	3/4 x 3/4					
1896ML	1/2 x 3/4	6 5/16	7 1/2	1 9/16	2 7/16	3 1/2
	3/4 x 3/4					

Note: All dimensions are in inches.

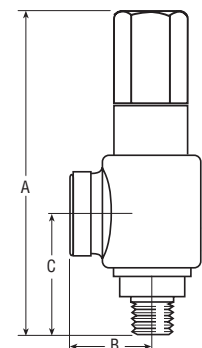

Farris Engineering

Division of Curtiss-Wright Flow Control Corporation

10195 Brecksville Road, Brecksville, OH 44141 USA • Telephone: 440/838-7690 • Fax: 440/838-7699 • www.cwfc.com

Facilities: Brecksville, OH USA, E. Farmingdale NY USA, Brantford, Ontario, Edmonton, Alberta

Offices: worldwide. For a listing of our global sales network, visit our website at www.cwfc.com.

While this information is presented in good faith and believed to be accurate, Curtiss-Wright Flow Control Corporation, Farris Engineering, does not guarantee satisfactory results from reliance on such information. Nothing contained herein is to be construed as a warranty or guarantee, expressed or implied, regarding the performance, merchantability, fitness or any other matter with respect to the products, nor as a recommendation to use any product or process in conflict with any patent. Curtiss-Wright Flow Control Corporation, Farris Engineering, reserves the right, without notice, to alter or improve the designs or specifications of the products described herein.

Printed in USA

9/99-5M-R2