

Type 3660 and 3661 Positioners

The Type 3660 pneumatic (see figure 1) or Type 3661 electro-pneumatic, single-acting positioners are used with various actuators on sliding-stem valves for throttling applications. These rugged positioners provide a valve position proportional to a pneumatic input or a standard milliampere dc input signal received from a control device.

Features

- **Accurate, Efficient, Vibration-Resistant Operation**—Positioner design provides accurate, fast-responding instruments able to withstand the vibrations of most plant environments. Low steady-state air consumption contributes to efficient operation.
- **Variable Gain**—Easily adjustable gain and damping adjustments fine tune the positioner stability to specific application requirements.
- **Versatility**—Positioner accepts a standard pneumatic input signal (Type 3660) or a standard milliampere dc input signal (Type 3661) from a control device. This positioner provides split range capabilities and adjustable zero and spans.
- **Fewer Spare Parts Required**—The Type 3660 and 3661 positioners are basically interchangeable, requiring fewer spare parts to support these positioners.
- **Easy Positioner Adjustments**—Zero and span adjustments can be made with the cover in place.
- **Rugged Construction**—The case and cover are designed to withstand mechanical vibration and rough handling.



W7174 / IL

Figure 1. Type 3660 Positioner with Baumann Actuator

- **Control Valve Diagnostic Testing Capability**—To support diagnostic testing of valve/actuator/positioner packages with the FlowScanner™ valve diagnostic system, connectors, piping, and other hardware can be installed between the Type 3660 or Type 3661 positioner and the actuator. A typical connector installation is shown in figure 5.



Specifications

Available Configuration

Type 3660: Single-acting pneumatic valve positioner

Type 3661: Single-acting electro-pneumatic valve positioner

Input Signal⁽¹⁾

Type 3660

■ 3 to 15 psig (0.2 to 1.0 bar), ■ 6 to 30 psig (0.4 to 2.0 bar), or ■ Split range, see table 1

Type 3661:

■ 4 to 20 mA dc constant current with 30 V dc maximum compliance voltage. ■ Split range is also available, see table 1

Equivalent Circuit

Type 3661: 120 ohms shunted by three 5.6 V zener diodes

Output Signal⁽¹⁾

Type: Pneumatic pressure as required by the actuator up to full supply pressure

Action: ■ Direct (increasing input signal increases positioner output), ■ Reverse (increasing input signal decreases positioner output)

Supply Pressure⁽¹⁾

Maximum: 90 psig (6.2 bar)

Recommended: 10% above actuator requirements

Performance⁽¹⁾

Independent Linearity: $\pm 1\%$ of output span.

Hysteresis: 0.5% of output span⁽⁴⁾.

Deadband: 0.1% of input span

Electromagnetic Interference (EMI):

Type 3661: When tested per SAMA Standard PMC 33.1-1978, change in steady-state deviation is less than $\pm 1\%$ in an electromagnetic field classified as 3-abc with a field strength of 30 V/m. Positioner is tested with cover on and with external wiring in rigid metal conduit.

These instruments have the CE mark in accordance with the Electromagnetic Compatibility (EMC) Directive. They meet the requirements of EN50081-1 (emissions for light

industry) and EN50082-2 (immunity for industrial environment).

Positioner Adjustments

Span: Adjustable from 0.75 to 2 inches (19 mm to 50 mm) stem travel.

Zero: 0 to 100%.

Gain: 0.5 to 6% PB (proportional band)⁽⁵⁾.

Output Volume Damping: Loop dynamic response adjustment.

Delivery Capacity⁽²⁾:

20 Psig (1.4 Bar) Supply: 150 scfh (4.3 normal m³/hour)

35 Psig (2.4 Bar) Supply: 230 scfh (6.6 normal m³/hour)

Exhaust Capacity⁽²⁾:

20 Psig (1.4 Bar) Supply: 170 scfh (4.8 normal m³/hour)

35 Psig (2.4 Bar) Supply: 260 scfh (7.4 normal m³/hour)

Steady-State Air Consumption⁽¹⁾⁽²⁾⁽³⁾

Type 3660: 6.0 scfh (0.16 normal m³/hour) at 20 psig (1.4 bar) supply pressure. 7.9 scfh (0.21 normal m³/hour) at 35 psig (2.4 bar) supply pressure

Type 3661: 8.8 scfh (0.2 normal m³/hour) at 20 psig (1.4 bar) supply pressure. 12.3 scfh (0.27 normal m³/hour) at 35 psig (2.4 bar) supply pressure

Operating Influences⁽¹⁾

Supply Pressure: 1 psig (69 mbar) change in supply pressure changes the actuator stem position less than 0.16%⁽⁶⁾ of the travel

Operative Temperature Limits⁽¹⁾

Type 3660 without Pressure Gauges: -40 to 250°F (-40 to 120°C)

Type 3660 with Pressure Gauges: -40 to 140°F (-40 to 60°C)

Type 3661 without Pressure Gauges: -40 to 180°F (-40 to 82°C)

Type 3661 with Pressure Gauges: -40 to 140°F (-40 to 60°C)

- Continued -

Product Bulletin

62.1:3660
September 2002

3660 and 3661 Positioners

Specifications (Continued)

Housing

NEMA 3 (FM), Enclosure 3 (CSA), IP 54 per IEC 529 Classification

Hazardous Area Classification

Refer to Hazardous Area Classification bulletin for approvals

Mounting

The positioner can be mounted in one of four different configurations. See figure 2.

Pressure Connections

1/4-inch NPT female

Conduit Connection for Type 3661

Conduit: 1/2-inch NPT (standard), M20 or PG13 adaptor (optional)

Maximum Valve Stem Travel

2 inch (50 mm); adjustable to obtain lesser travel with standard input signal—minimum 0.75 inch (19 mm)

Construction Materials

See table 2

Options

Type 3660:

- Instrument and output pressure gauges,
- Integrally mounted bypass valve

Type 3661: Output pressure gauge

Type 3660 and 3661: Connectors for diagnostic testing ■ stainless steel or ■ brass

Approximate Weight

Type 3660: 2.6 pounds (1.2 kg)

Type 3661: 3.0 pounds (1.4 kg)

Vent Connection

1/4-inch NPT female

1. This term is defined in ISA Standard S51.1:1979.
2. Scfh--standard cubic feet per hour (60°F and 14.7 psia). Normal m³/hr--normal cubic meters per hour (0°C and 1.01325 bar absolute).
3. Air consumption at a gain setting of 1/2 turn.
4. Hysteresis value at a gain setting of 1/2 turn.
5. Adjusting the gain (PB) adjustment will change the nozzle flapper relationship. This nozzle flapper change affects the actuator/positioner response time.
6. At supply pressure of 35 psig (2.4 bar).

Table 1. Standard and Split Range Capabilities

TYPE	3660		3660		3661
	3 to 15 Psig (0.2 to 1.0 bars) Input Signal		6 to 30 Psig (0.4 to 2.0 psig) Input Signal		
	Psig	Bar	Psig	Bar	
One Way 1:1	3 to 15	0.2 to 1.0	6 to 30	0.4 to 2.0	4 to 20
Two Way 2:1	3 to 9 9 to 15	0.2 to 0.6 0.6 to 1.0	6 to 18 18 to 30	0.4 to 1.2 1.2 to 2.0	4 to 12 12 to 20
Three Way 3:1	3 to 7 7 to 11 11 to 15	0.2 to 0.5 0.5 to 0.8 0.8 to 1.0	6 to 14 14 to 22 22 to 30	0.4 to 1.0 1.0 to 1.6 1.6 to 2.0	4 to 9.33 9.33 to 14.66 14.66 to 20
Four Way 4:1	3 to 6 6 to 9 9 to 12 12 to 15	0.2 to 0.4 0.4 to 0.6 0.6 to 0.8 0.8 to 1.0	6 to 12 12 to 18 18 to 24 24 to 30	0.4 to 0.8 0.8 to 1.2 1.2 to 1.6 1.6 to 2.0	4 to 8 8 to 12 12 to 16 16 to 20

Table 2. Construction Materials

PART	MATERIAL	
	Standard	Optional
Case and Cover	Aluminum	---
Feedback Lever Assembly	Stainless Steel	---
Range Spring	NI Span C	---
Input Module	ECO	
Diaphragm Relay	EPDM	---
Gasket	Silicon Rubber	
O-Ring	Ethylene/Propylene	
Nozzle	Aluminum	---
Flapper	Aluminum	---
Relay Metal Parts	Aluminum and Stainless Steel	---
Gauges	Brass and Plastic	---
All Fasteners	Stainless Steel	
Exterior Tubing and Fitting	Copper/Brass	Stainless Steel
Connectors for Diagnostic Testing	Stainless Steel or Brass	---

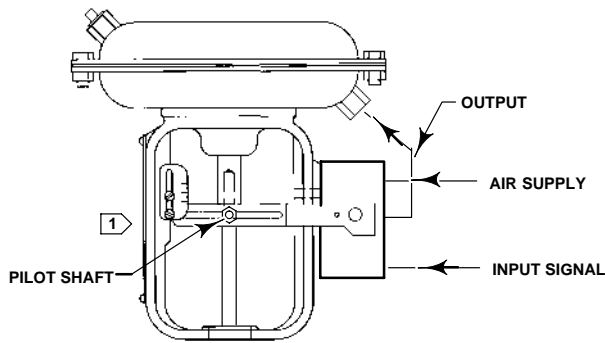

ACTUATOR: AIR-TO-RETRACT
POSITIONER ACTION: DIRECT
(INCREASING INPUT SIGNAL INCREASES
OUTPUT PRESSURE TO ACTUATOR)

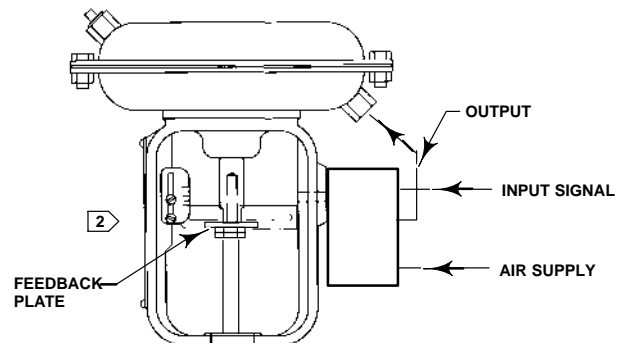

ACTUATOR: AIR-TO-RETRACT
POSITIONER ACTION: REVERSE
(INCREASING INPUT SIGNAL DECREASES
OUTPUT PRESSURE TO ACTUATOR)

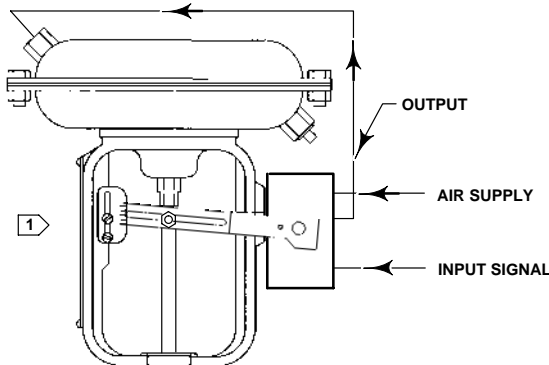

ACTUATOR: AIR-TO-EXTEND
POSITIONER ACTION: REVERSE
(INCREASING INPUT SIGNAL DECREASES
OUTPUT PRESSURE TO ACTUATOR)

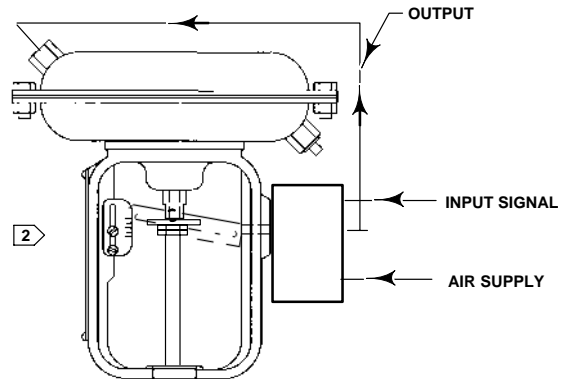

ACTUATOR: AIR-TO-EXTEND
POSITIONER ACTION: DIRECT
(INCREASING INPUT SIGNAL INCREASES
OUTPUT PRESSURE TO ACTUATOR)

NOTES:

1 WHEN MOUNTING ON BAUMANN ACTUATORS, INSTALL FEEDBACK PLATE SO LIP IS UP. INSTALL FEEDBACK LEVER ARM ASSEMBLY SO PILOT SHAFT IS ON TOP OF THE FEEDBACK PLATE.

2 WHEN MOUNTING ON BAUMANN ACTUATORS, INSTALL FEEDBACK PLATE SO LIP IS DOWN. INSTALL FEEDBACK LEVER ARM ASSEMBLY SO PILOT SHAFT IS UNDERNEATH THE FEEDBACK PLATE.

17B9106-B
17B9105-B
38B0195-B
A4035-2 / IL

Figure 2. Mounting Configurations (See Table 3 for Positioner Action and Signals)

Table 3. Positioner Input Signal, Action, and Output Signal

Input Signal	Positioner Output
Direct 3 to 15 psig (0.2 to 1.0 bar) 6 to 30 psig (0.4 to 2.0 bar) 4 to 20 mA	Up to 90 psig (6.2 bar)
Reverse 15 to 3 psig (1.0 to 0.2 bar) 30 to 6 psig (2.0 to 0.4 bar) 20 to 4 mA	
For split range signal refer to table 1	

Principle of Operation

Refer to figure 3 for operational schematic.

The instrument pressure acts on the input module, which controls the flapper-nozzle system of the relay. Supply pressure is applied to the relay, and

the output pressure of the relay is supplied to the control valve actuator.

For a direct-acting positioner, increases in instrument pressure causes the input module to pivot the beam. The beam pivots the flapper and restricts the nozzle. The nozzle pressure increases and causes the relay assembly to increase output pressure to the actuator. With a direct-acting actuator, this increased pressure moves the actuator stem downward. Stem movement is fed back to the beam by means of a feedback lever and range spring, which cause the flapper to pivot slightly away from the nozzle to prevent any further increases in relay output pressure. The positioner is once again in equilibrium but at a higher instrument pressure, a slightly different flapper position, and a new actuator stem position.

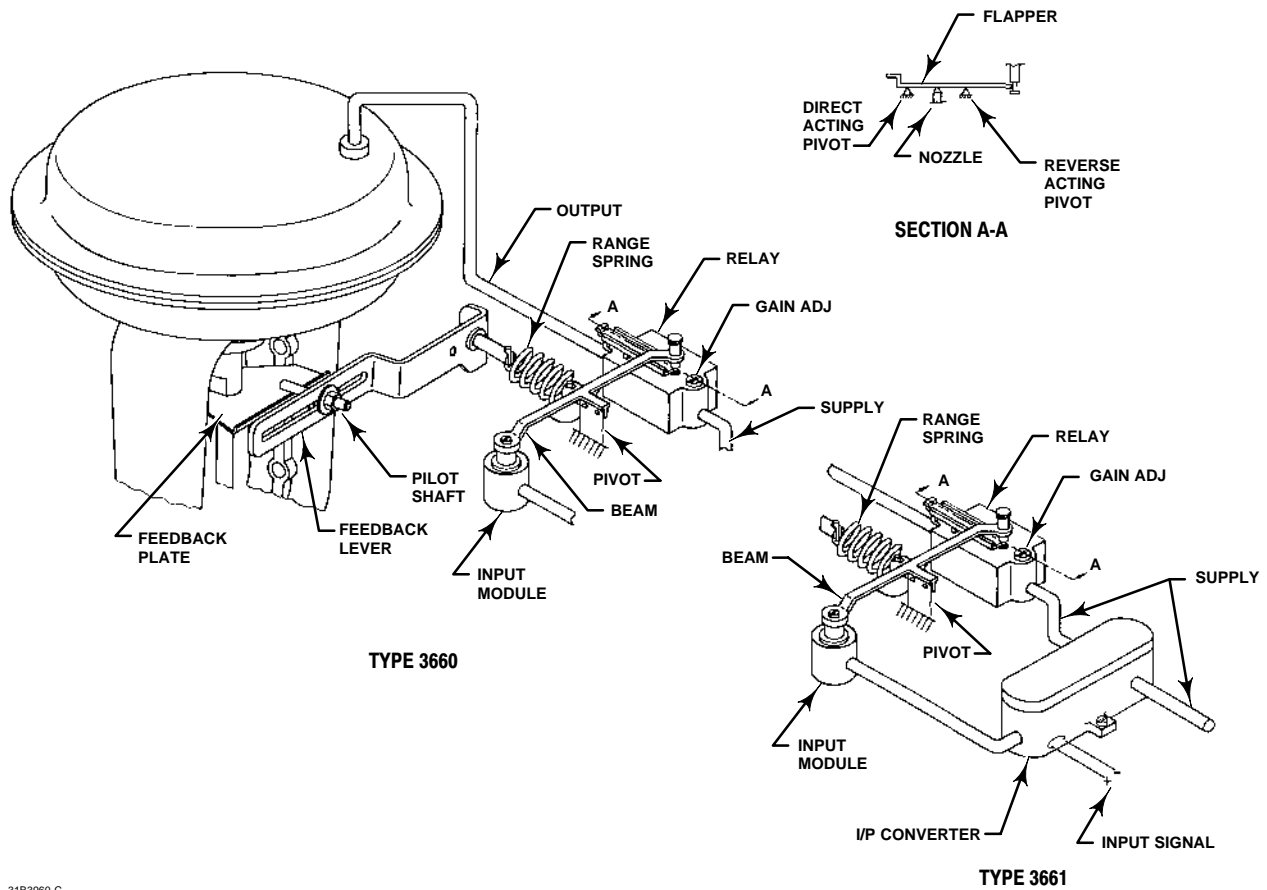

31B3960-C
B2152-4 / IL

Figure 3. Operational Schematic

A decrease in instrument pressure decreases nozzle pressure, which allows the relay to bleed off actuator loading pressure.

Operation of a reverse-acting positioner is similar except that the flapper position is reversed from that shown in figure 3. The reversed position uses the alternate flapper pivot point so that increases in

instrument pressure rotate the flapper away from the nozzle to reduce nozzle pressure.

With a Type 3661 electro-pneumatic positioner, the electro-pneumatic converter provides a 3 to 15 psig (0.2 to 1.0 bar) output pressure proportional to the 4 to 20 milliamper input signal. The 3 to 15 psig (0.2 to 1.0 bar) output pressure becomes the input signal pressure to the input module.

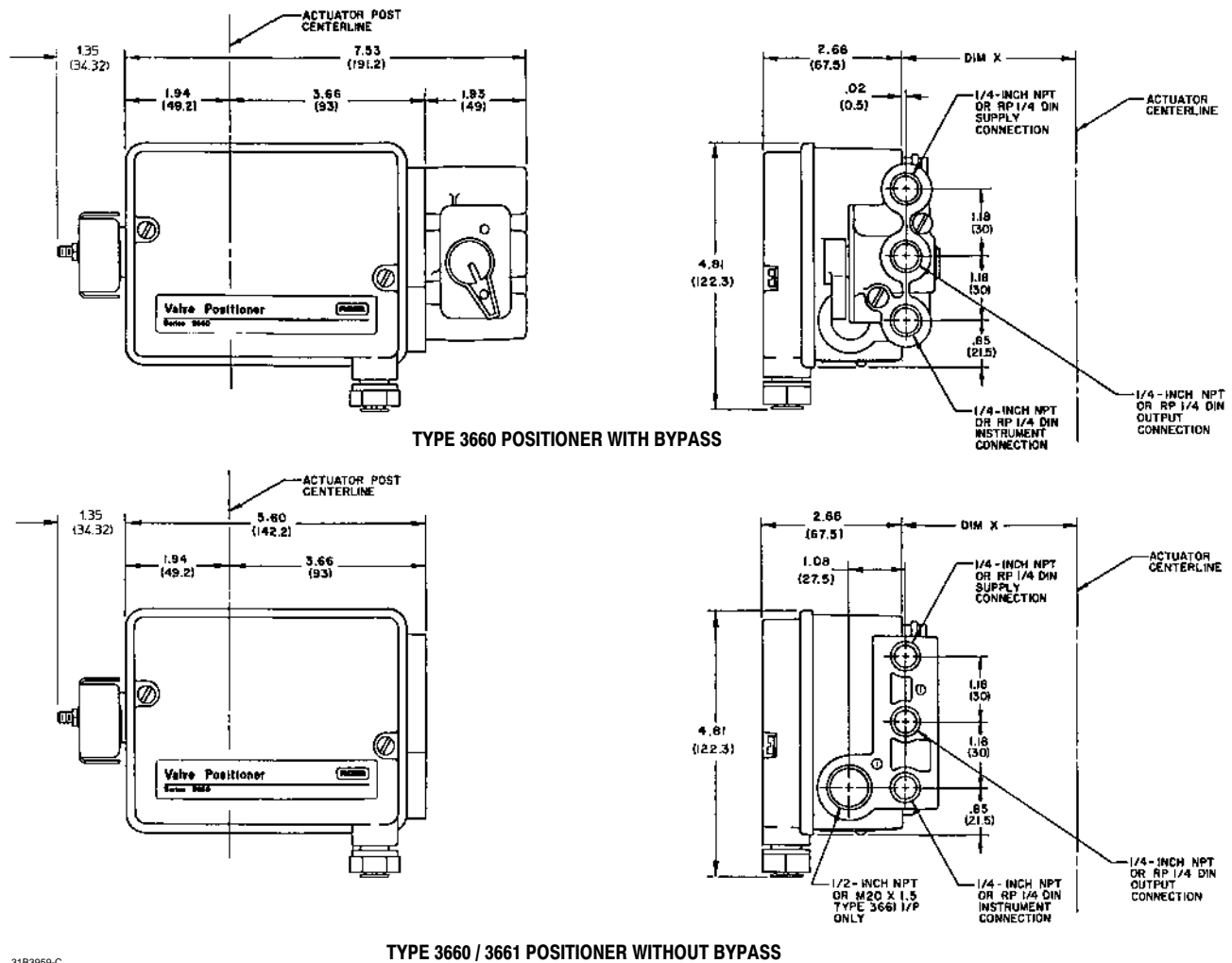

Figure 4. Positioner Dimensions and Connections (See Table 4 for the X Dimension)

Table 4. Dimension X

ACTUATOR CENTERLINE TO POSITIONER			
Type	Size	Dim X	
		Inch	mm
657/667	30	3.63	92.2
	34	3.75	95.3
	40	4.13	104.9
	45/46	4.25	108.0
	50/60	5.06	128.5
1250	225	3.39	86
	450	3.39	86
	675	4.33	110
3024S	1.21	3.29	83.5
	1.31	3.44	87.5
	1.41	3.44	87.5
Baumann	16In ²	2.12	53.8
	32In ²	2.81	71.4
	54In ²	2.81	71.4
	70In ²	2.81	71.4

Installation

The supply pressure medium should be clean, dry, filtered air. If the supply source is capable of exceeding the maximum actuator operating pressure or positioner supply pressure, appropriate steps must be taken during installation to protect the positioner and all connected equipment against overpressure.

Overall dimensions and connections are shown in figure 4 and table 4.

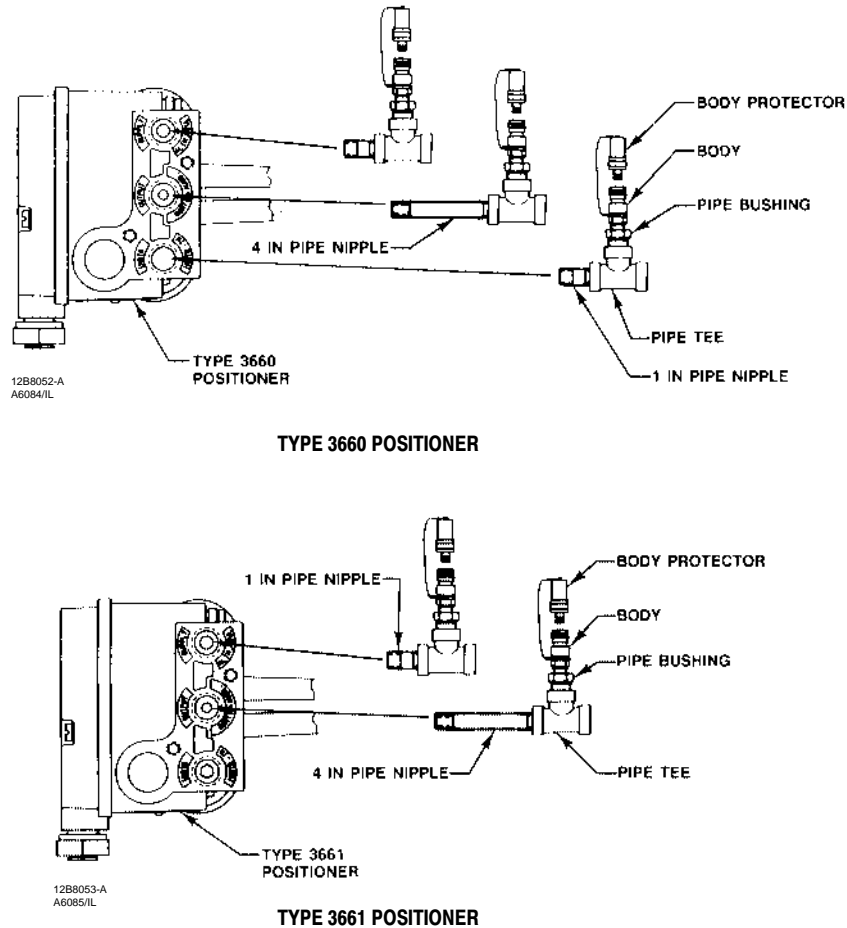

Figure 5. FlowScanner Diagnostic System Connections

Ordering Information

Application

Note: Fisher does not assume responsibility for the selection, use, or maintenance of any product. Responsibility for proper selection, use, and maintenance of any Fisher product remains solely with the purchaser and end user.

When ordering, specify:

1. Type number
2. Input signal range: pneumatic or milliamperes
3. Maximum supply pressure available
4. Valve plug travel: actuator type and size
5. Stroking time requirements, if critical
6. Ambient temperature range
7. Direct or reverse acting
8. Supply pressure regulator, gauges, and bypass, if required
9. Hazardous area classification (Type 3661)
10. Connectors for diagnostic testing, if required

Fisher and FlowScanner are marks owned by Fisher Controls International, Inc., a business of Emerson Process Management. The Emerson logo is a trademark and service mark of Emerson Electric Co. All other marks are the property of their respective owners.

The contents of this publication are presented for informational purposes only, and while every effort has been made to ensure their accuracy, they are not to be construed as warranties or guarantees, express or implied, regarding the products or services described herein or their use or applicability. We reserve the right to modify or improve the designs or specifications of such products at any time without notice.

Fisher does not assume responsibility for the selection, use or maintenance of any product. Responsibility for proper selection, use and maintenance of any Fisher product remains solely with the purchaser and end-user.

Emerson Process Management

Fisher

Marshalltown, Iowa 50158 USA

Cernay 68700 France

Sao Paulo 05424 Brazil

Singapore 128461

www.Fisher.com

