

3582 Series Pneumatic and Type 3582i Electro-Pneumatic Valve Positioners

The 3582 Series pneumatic valve positioners, shown in figure 1, and the Type 3582i electro-pneumatic valve positioners, shown in figure 2, are used with diaphragm-actuated, sliding-stem control valve assemblies. The pneumatic valve positioners receive a pneumatic input signal from a control device and modulate the supply pressure to the control valve actuator, providing an accurate valve stem position that is proportional to the pneumatic input signal.

Type 3582NS positioners meet typical requirements of the nuclear power industry. The Type 3582NS construction includes materials that provide superior performance at elevated temperature and radiation levels. The O-rings are EPDM (ethylene propylene) and the diaphragms are EPDM/Nomex. EPDM demonstrates superior temperature capability and shelf life over nitrile. (Use a clean, dry, oil-free air supply with instruments containing EPDM components. EPDM is subject to degradation when exposed to petroleum-based lubricants.) The Nomex diaphragm fabric demonstrates improved strength retention at elevated temperature and radiation conditions.

In addition, the Type 3582NS positioner is qualified "commercial grade dedicated" under Fisher's 10CFR50, Appendix B, quality assurance program. These can be supplied as 10CFR21 items.

The Type 3582i electro-pneumatic valve positioner consists of a Type 582i electro-pneumatic converter installed on a Type 3582 pneumatic valve positioner. The Type 3582i provides an accurate valve stem position that is proportional to a dc current input signal.

The Type 582i electro-pneumatic converter, shown in figure 5, is a modular unit that can be installed at the factory or in the field. (Upgrading an existing 3582 Series unit by field installation of a Type 582i electro-pneumatic converter may require changing the existing positioner mounting and the input signal range. Please contact your Fisher sales office when planning an upgrade). The converter receives a dc current input signal and provides a proportional



W5498-1/IL

Figure 1. Typical 3582 Series Pneumatic Valve Positioner with Actuator and Valve



W8152/IL

Figure 2. Type 3582i Electro-Pneumatic Valve Positioner

pneumatic output signal through a nozzle/flapper arrangement. The pneumatic output signal provides the input signal to the pneumatic positioner, eliminating the need for a remote mounted transducer.



Specifications

Available Configurations

Refer to the Type Number Description

Input Signal⁽¹⁾

For 3582 Series.

■ 0.2 to 1.0 bar (3 to 15 psig), ■ 0.4 to 2.0 bar (6 to 30 psig), or ■ split range, see table 1.

For Type 3582i Only.

4 to 20 mA dc constant current with 30 Vdc maximum compliance voltage, can be split range, see table 1

Equivalent Circuit

For Type 3582i Only:

120 ohms shunted by three 5.6-volt zener diodes, see figure 3

Output Signal⁽¹⁾

Type: Pneumatic pressure as required by actuator up to 95 percent of maximum supply

Action⁽¹⁾: Field-reversible between ■ direct and ■ reverse within the pneumatic valve positioner

Supply Pressure⁽¹⁾

Recommended: 0.3 bar (5 psi) above actuator requirement

Maximum: 3.4 bar (50 psig) or pressure rating of actuator, whichever is lower

Maximum Input Bellows Pressure Rating

2.4 bar (35 psig)

Maximum Steady-State Air Consumption⁽¹⁾⁽²⁾

For 3582 Series.

1.4 bar (20 psig) Supply: 0.38 normal m³/hr (14.0 scfh)

2.0 bar (30 psig) Supply: 0.48 normal m³/hr (18.0 scfh)

2.4 bar (35 psig) Supply: 0.54 normal m³/hr (20.0 scfh)

For Type 3582i Only.

1.4 bar (20 psig) Supply: 0.42 normal m³/hr (17.2 scfh)

2.0 bar (30 psig) Supply: 0.53 normal m³/hr (21 scfh)

2.4 bar (35 psig) Supply: 0.59 normal m³/hr (24 scfh)

Maximum Supply Air Demand⁽¹⁾⁽²⁾

For 3582 Series and Type 3582i.

1.4 bar (20 psig) Supply: 4.7 normal m³/hr (164.5 scfh)

2.0 bar (30 psig) Supply: 7.0 normal m³/hr (248.5 scfh)

2.4 bar (35 psig) Supply: 8.1 normal m³/hr (285.5 scfh)

Performance

For 3582 Series.

Independent Linearity⁽¹⁾: ±1 percent of output signal span

Hysteresis⁽¹⁾: 0.5 percent of span

For Type 3582i Only.

Independent Linearity⁽¹⁾: ±2 percent of output signal span

Hysteresis⁽¹⁾: 0.6 percent of span

Electromagnetic Interference (EMI)⁽¹⁾: When tested per IEC 801-3 (1984), change in steady-state deviation is less than ±1% at an electromagnetic field strength of 30 V/m from 20 to 1000 MHz. Positioner is tested with housing cap on and with external field wiring in rigid metal conduit.

For 3582 Series and Type 3582i.

Open Loop Gain (Output Signal)⁽¹⁾:

■ 100 in the range of 0.2 to 1.0 bar (3 to 15 psig)

■ 55 in the range of 0.4 to 2.0 bar (6 to 30 psig)

Operating Influences⁽¹⁾

Supply Pressure, For 3582 Series Units. Valve travel changes less than 1.67 percent per bar (0.25 percent per 2 psi) change in supply pressure

Supply Pressure, For Type 3582i Units. Valve travel changes less than 3.62 percent per bar (1.5 percent per 2 psi) change in supply pressure

Electrical Classification

For Type 3582i Only:

Refer to the Hazardous Area Classifications Bulletin for specific approvals.

Housing Classification

For Type 3582i Only.

NEMA 3, IEC 60529 IP54: Mounting orientation requires vent location to be below horizontal

- continued -

Specifications (Continued)

Operative Temperature Limits⁽¹⁾

Standard Construction, For 3582 Series and Type 3582i Units: -40 to +71°C (-40 to +160°F)
Type 3582NS Units: -40 to +82°C (-40 to +180°F) with EPDM elastomers
High-Temperature Construction⁽³⁾, For Types 3582A and C Only: -18 to +104°C (0 to +220°F)

Construction Materials

Positioner

Case: Low copper aluminum alloy
Cover: Impact-resistant plastic
Bellows: Phosphor bronze
O-Rings..
All 3582 except 3582NS: ■ Nitrile (standard) or ■ Fluoroelastomer (high-temperature)
Type 3582NS: EPDM
Connectors for Diagnostic Testing: ■ Stainless steel or ■ Brass

Relay

Castings: Aluminum
Diaphragms.
All 3582 except 3582NS: ■ Nitrile-Dacron (standard) or ■ Polyacrylate-Nylon (high-temperature)
Type 3582NS: EPDM/Nomex
O-Rings.
All 3582 except 3582NS: ■ Nitrile (standard) or ■ Fluoroelastomer (high-temperature)
Type 3582NS: EPDM
Gaskets: ■ Nitrile-Dacron (standard) or ■ Poly-acrylate-Nylon (high-temperature)
Type 582i Converter

Case and Cover: Low-copper aluminum alloy
O-Rings: Nitrile

Pressure Gauges

40 mm (1-1/2 inch) diameter with plastic case and brass connection
 ■ triple scale (PSI, MPa, and bar) or
 ■ dual scale (PSI and kg/cm²)

Pressure Connections

1/4-inch NPT female

Electrical Connection

For Type 3582i only:
 1/2-14 NPT conduit connection

Maximum Valve Stem Travel

105 mm (4-1/8 inches); adjustable to obtain lesser travel with standard input signal

Characterized Cams

See characterized cams section

Approximate Weight

3582 Series Units: 2.5 kg (5-1/2 pounds)
Type 3582i: 3.6 kg (8 pounds)

Options

■ Instrument, output, and supply pressure gauges; automotive tire valves; or pipe plugs (see Type Number Description section) ■ Bypass valve (only for direct-acting, 3582 Series units using a full input signal range) and ■ Type SS-52 clip-on test pressure gauge (for both 3582 Series and Type 3582i units equipped with automotive tire valves), ■ Characterized cams B and C
 ■ Connectors for diagnostic testing

1. This term is defined in ISA Standard S51.1

2. Normal m³/hr--normal cubic meters per hour (0°C and 1.01325 bar absolute); Scfh--standard cubic feet per hour (60°F and 14.7 psia)

3. Not available with bypass or pressure gauges.

Features

- **Versatile Modular Design**—The 3582 Series unit can be upgraded in the field to an electro-pneumatic Type 3582i by replacing the gauge block with the Type 582i electro-pneumatic converter (figure 5) assembly. (Upgrading an existing 3582 Series unit by field installation of a Type 582i

electro-pneumatic converter may require changing the existing positioner mounting and the input signal range. Please contact your Fisher sales office when planning an upgrade). The converter assembly attaches to the positioner case, providing a cost-effective conversion. Thus, in the field, 3582 Series units can be upgraded from pneumatic to electronic to match new control strategies.

Table 1. Split-Range Capabilities

3582 SERIES POSITIONERS				
Split	0.2 to 1.0 Bar or 3 to 15 Psig Input Signal		0.4 to 2.0 Bar or 6 to 30 Psig Input Signal	
	Bar	Psig	Bar	Psig
Two-way	0.2 to 0.6 0.6 to 1.0	3 to 9 9 to 15	0.4 to 1.2 1.2 to 2.0	6 to 18 18 to 30
Three-way	0.2 to 0.5 0.5 to 0.7 0.7 to 1.0	3 to 7 7 to 11 11 to 15	0.4 to 0.9 0.9 to 1.5 1.5 to 2.0	6 to 14 14 to 22 22 to 30
TYPE 3582i POSITIONER				
Split	4 to 20 Milliampere Input Signal			
Two-way	4 to 12 12 to 20			
Three-way	4 to 9.3 9.3 to 14.7 14.7 to 20			

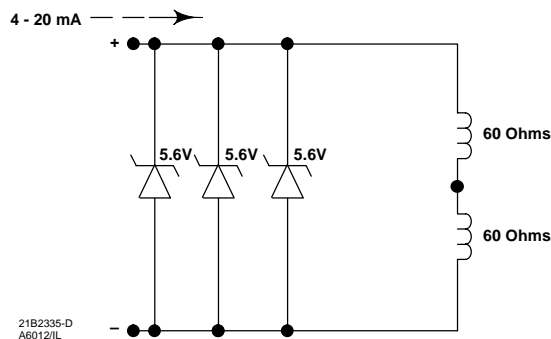

Figure 3. Equivalent Circuit

● **Accurate, Efficient, Vibration-Resistant Operation**—The 3582 Series and the Type 3582i positioners offer a field-proven positioner design which is accurate, fast-responding and able to withstand the vibrations of most plant environments. Low steady-state air consumption contributes to efficient operation.

● **Rangeability**—Both the 3582 Series and the Type 3582i positioners provide split range capabilities. The range of the adjustable zero and span permits the use of all standard input signals including split ranges.

● **Simplified Spare Parts Inventories**—Because units from one positioner family can be used in a variety of control applications, basic spare parts inventory requirements are simplified and fewer spare parts are needed to support a plant-wide positioner applications base.

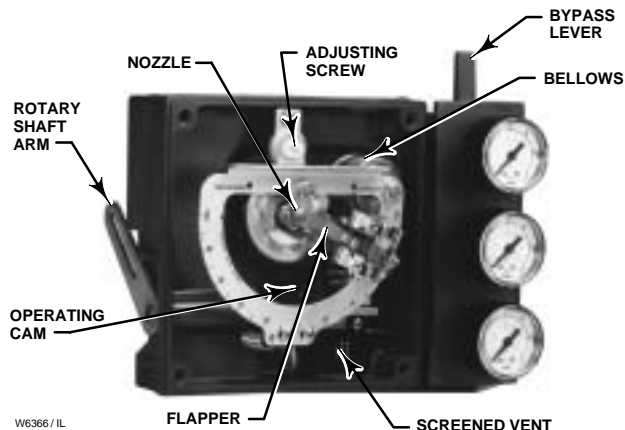

Figure 4. Type 3582 Pneumatic Valve Positioner Mechanism



Figure 5. Type 3582i Electro-Pneumatic Converter

● **Easy Positioner Adjustments**—With the cover removed, as shown in figure 4, zero and span adjustments are easily accessible and can be made with common hand tools.

● **Stable Operation**—Changes in supply pressure and valve load have minimal effect on positioner operation.

● **Corrosion Resistance**—Case, components, and gasket materials withstand harsh environments. Positioner bleed air purges internal parts for additional protection.

● **Field Reversible**—Simple adjustments permit switching between direct and reverse action.

● **Control Valve Diagnostic Testing Capability**—To support diagnostic testing of valve/actuator/positioner packages with the FlowScanner™ valve diagnostic system, connectors, piping, and other hardware can be installed between the 3582 Series or Type 3582i and the actuator.

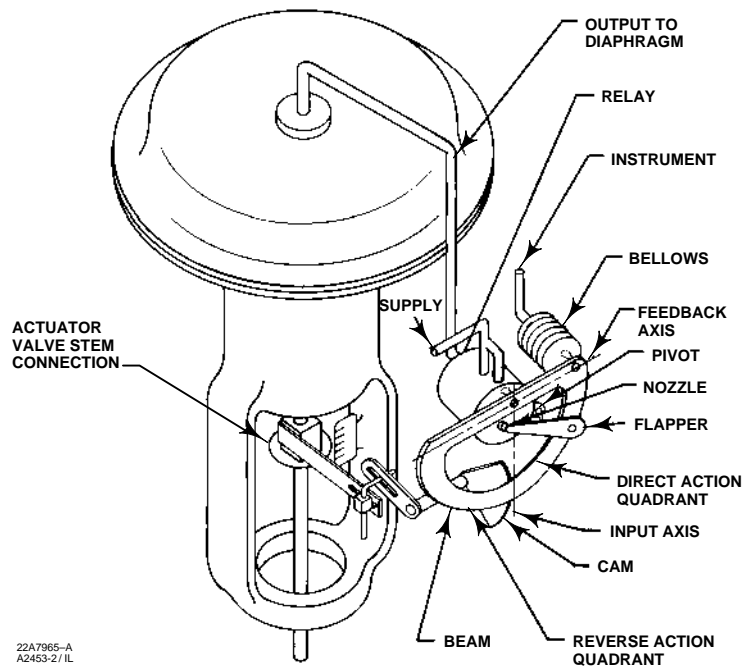

Figure 6. Schematic Diagram of 3582 Series Positioner

Type Number Description

Type 3582—Pneumatic valve positioner with bypass and instrument, supply, and output pressure gauges.

Type 3582A—Pneumatic valve positioner without bypass and without pressure gauges.

Type 3582C—Pneumatic valve positioner without bypass and with automotive tire valves instead of pressure gauges.

Type 3582D—Pneumatic valve positioner with bypass and with automotive tire valves instead of pressure gauges.

Type 3582G—Pneumatic valve positioner without bypass and with instrument, supply, and output pressure gauges.

Type 3582NS—Pneumatic valve positioner for nuclear service applications with or without bypass and with automotive tire valves instead of pressure gauges.

Type 3582i—Electro-pneumatic valve positioner without bypass; with Type 582i converter; and with:

■ supply and output pressure gauges, ■ automotive tire valves, or ■ pipe plugs.

Type 582i—Electro-pneumatic converter with: ■ supply and output pressure gauges, ■ automotive tire valves, or ■ pipe plugs. Used for conversion of a 4 to 20 milliampere input signal to a 0.2 to 1.0 bar (3 to 15 psig) input signal for the pneumatic valve positioner.

Type 83L—Pneumatic relay included as part of both the 3582 Series positioners and the Type 3582i positioner.

Principle of Operation

The 3582 Series (Type 3582, 3582NS and Types 3582A, C, D, and G pneumatic valve positioners) accept a pneumatic input signal from a control device. The operational schematic in figure 6 depicts the direct-acting pneumatic valve positioner.

Supply pressure is connected to the Type 83L relay. A fixed restriction in the relay limits flow to the nozzle so that when the flapper is not restricting the nozzle, air can bleed out faster than it is being supplied.

3582 and 3582i Valve Positioners

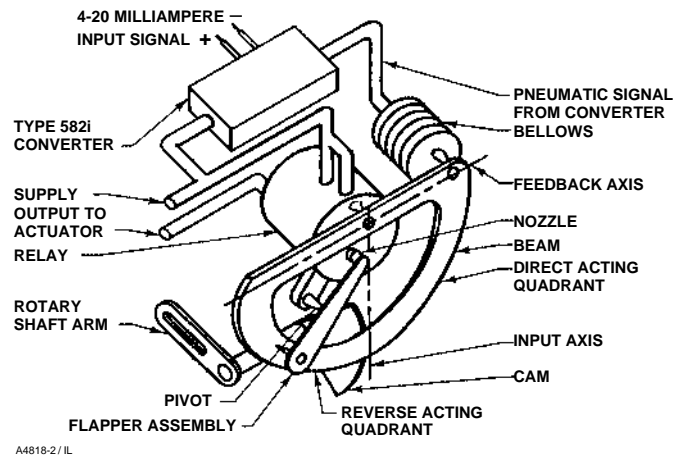

Figure 7. Schematic Diagram of Type 3582i Positioner

The input signal from the control device is connected to the bellows. When the input signal increases, the bellows expands and moves the beam. The beam pivots about the input axis moving the flapper closer to the nozzle. The nozzle pressure increases and, through relay action, increases the output pressure to the diaphragm actuator. The increased output pressure to the actuator causes the actuator stem to move downward. Stem movement is fed back to the beam by means of a cam. As the cam rotates, the beam pivots about the feedback axis to move the flapper slightly away from the nozzle. The nozzle pressure decreases and reduces the output pressure to the actuator. Stem movement continues, backing the flapper away from the nozzle, until equilibrium is reached.

When the input signal decreases, the bellows contracts (aided by an internal range spring) and the beam pivots about the input axis to move the flapper away from the nozzle. Nozzle pressure decreases and the relay permits the release of diaphragm casing pressure to atmosphere. The actuator stem moves upward. Through the cam, stem movement is fed back to the beam to reposition the flapper closer to the nozzle. When equilibrium conditions are obtained, stem movement stops and the flapper is positioned to prevent any further decrease in diaphragm case pressure.

The principle of operation for reverse acting units is similar except that as the input signal increases, the diaphragm casing pressure is decreased. Conversely, a decreasing input signal causes an increase in the pressure to the diaphragm casing.

As shown in figure 7, the Type 3582i electro-pneumatic positioner accepts a dc current input signal provided to the Type 582i electro-pneumatic converter attached to the positioner. The Type 582i provides the pneumatic input signal pressure used by the pneumatic positioner.

Characterized Cams

Three cams are available for the 3582 Series valve positioners. A linear cam (cam A) is supplied with the unit. Two characterized cams (cams B and C) are available as options. Figure 8 shows the resultant stem travel due to an incremental instrument pressure change for each cam. When the linear cam is the operating cam, there is a linear relationship between an incremental input signal change and valve travel, and the flow characteristic of the valve is that of the control valve. When either characterized cam is the operating cam, the relationship between an incremental input signal

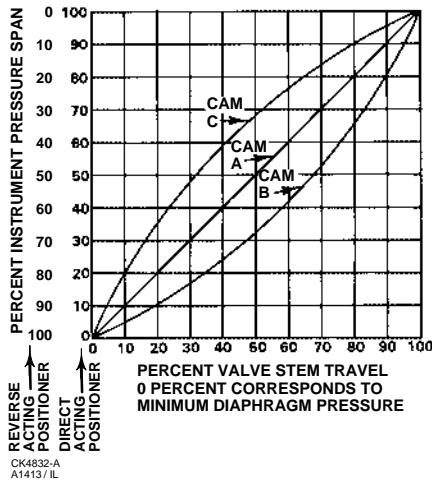

Figure 8. Instrument Pressure Versus Valve Travel

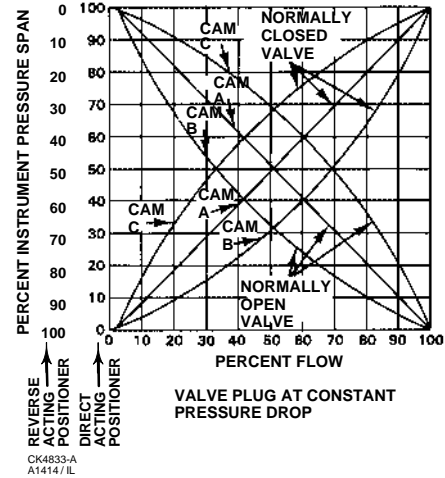

Figure 10. Linear Valve Flow Characteristics as Modified by Various Cams

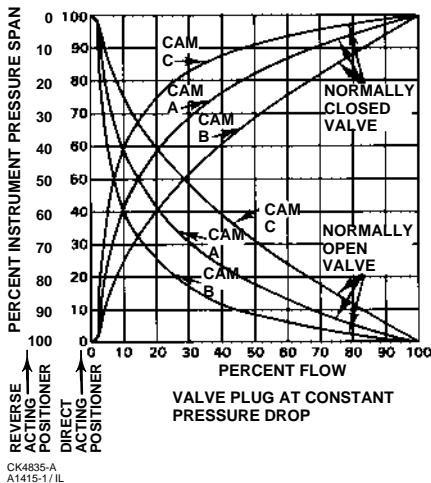

Figure 9. Equal Percentage Valve Flow Characteristics as Modified by Various Cams

change and valve travel changes thereby modifying the valve flow characteristics. Figure 9 shows how the characteristic is modified for an equal percentage valve. Figure 10 shows how the characteristic is modified for a linear valve.

Since the 3582 Series positioner mounts the same way on either direct-acting or reverse-acting diaphragm actuators, the cams are reversible.

Installation

Figure 11 shows a typical positioner mounting for a direct- or reverse-acting actuator. Positioner overall dimensions and connections are shown in figure 11 and table 2.

3582 and 3582i Valve Positioners

Table 2. Dimensions

STEM TRAVEL		X					
		9.5 mm (3/8 inch) Stem		12.7 mm (1/2 inch) Stem		19.1 mm (3/4 inch) Stem	
mm	Inch	mm	Inch	mm	Inch	mm	Inch
29 or less	1-1/8 or less	81	3.19	87	3.44	100	3.94
38	1-1/2	90	3.56	97	3.81	109	4.31
51	2	102	4.00	108	4.25	121	4.75
64	2-1/2	113	4.44	119	4.69	132	5.19
76	3	124	4.88	130	5.12	143	5.62
89	3-1/2	135	5.31	141	5.56	154	6.06
102	4	146	5.75	152	6.00	165	6.50

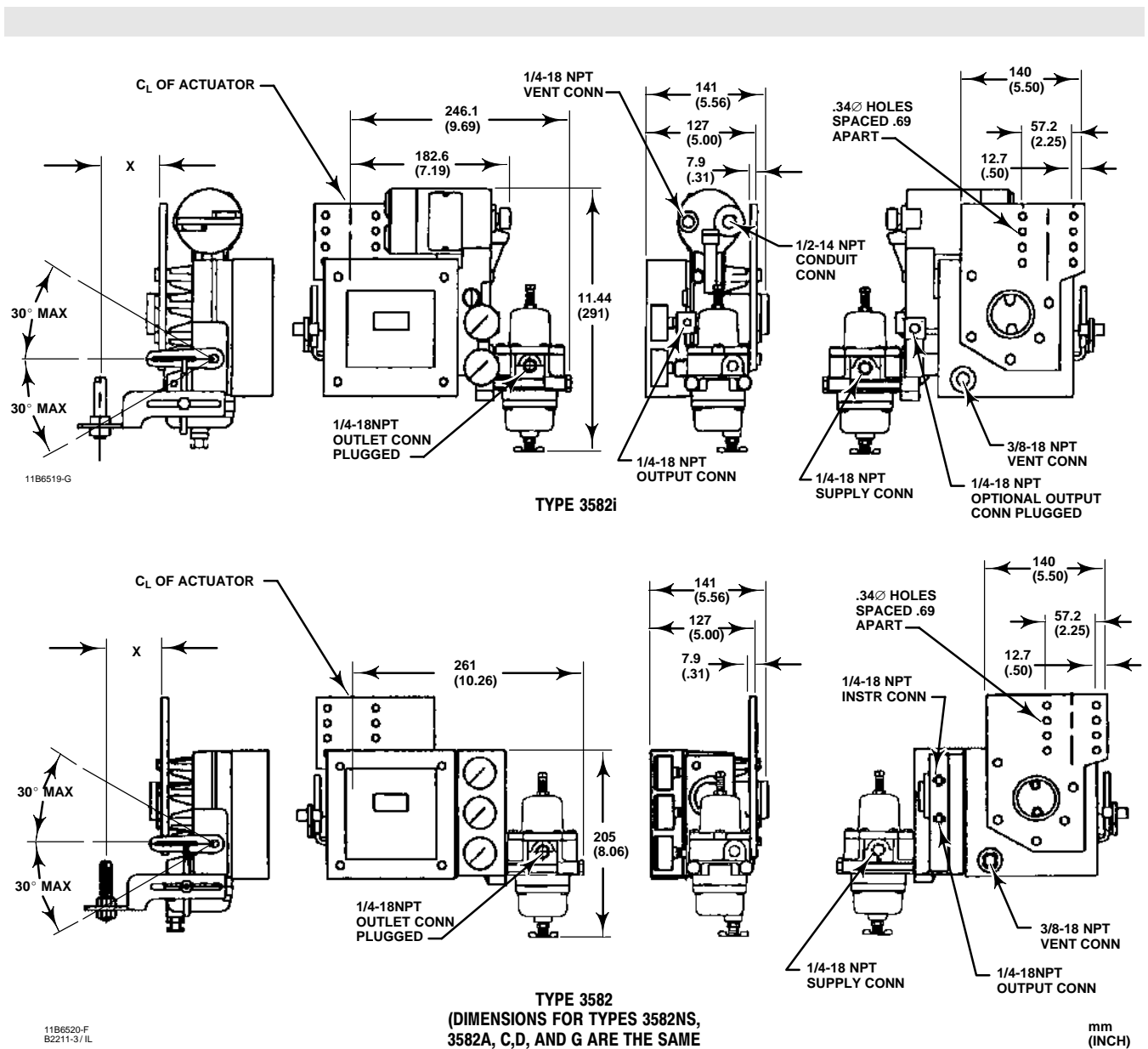

Figure 11. Valve Positioner Dimensions and Connections (also see table 2)

Ordering Information

When ordering, please specify the product application and construction:

Application

1. Positioner type number. When ordering a Type 3582i electro-pneumatic positioner, specify:

■ supply and output pressure gauges, ■ automotive tire valves, or ■ pipe plugs.

2. Maximum supply pressure available

3. Direct or reverse acting

4. Valve stroke in inches; actuator type and size

5. Initial cam set-up (cam A, B, or C)

6. Input signal

7. Supply pressure regulator and test pressure gauge.

8. Connectors for diagnostic testing, if required.

Construction

Refer to the specifications. Carefully review each specification; indicate your choice whenever a selection is offered.

Fisher and FlowScanner are marks owned by Fisher Controls International, Inc., a business of Emerson Process Management. The Emerson logo is a trademark and service mark of Emerson Electric Co. All other marks are the property of their respective owners.

The contents of this publication are presented for informational purposes only, and while every effort has been made to ensure their accuracy, they are not to be construed as warranties or guarantees, express or implied, regarding the products or services described herein or their use or applicability. We reserve the right to modify or improve the designs or specifications of such products at any time without notice.

Fisher does not assume responsibility for the selection, use or maintenance of any product. Responsibility for proper selection, use and maintenance of any Fisher product remains solely with the purchaser and end-user.

Emerson Process Management

Fisher

Marshalltown, Iowa 50158 USA

Cernay 68700 France

Sao Paulo 05424 Brazil

Singapore 128461

www.Fisher.com

