

THE TRI-CON SERIES. THE SERIES THAT KEEPS ITS PROMISE



THE TRI-CON SERIES

A METAL SEATED-TRIPLE OFF-SET



ZWICK
ARMATUREN GMBH

ZWICK ARMATUREN GMBH: MAXIMUM PERFORMANCE WITH KNOW-HOW „MADE IN GERMANY“

*T*his valve demands a high level of expertise and a high quality of machining. With over 10 years of experience in research, development and manufacturing we ensure the TRI-CON series will meet or exceed the specifications required by the industry standards.



The Company's Quality Assurance is certified to ISO 9001, but this is not our final goal. The sealing members being the laminated seal ring and the solid seat, are manufactured in stainless steel. Therefore, the TRI-CON valve has become one of the most global applied valves in the market.



The mono flanged bodies according to API 609 and DIN 3202 and the double flanged bodies according to ISO 5752, B16.10 and DIN 3202, also butt weld valves are within the standard series.

The valve is widely proved in high demanding industries: from oxygen up to exhausted gases, cryogenic and superheated steam and also in widely used chemical process industries.

The valve is used in the petrochemical and chemical industry for process and control providing excellent flow characteristics. The sealing design eliminates breakaway torques.

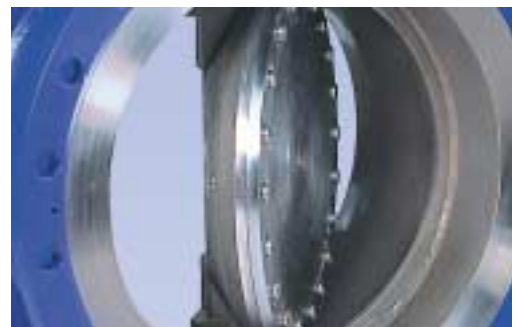

The Zwick Armaturen capability includes process valves of the TRI-CON Series as well as a wide range of special valves.

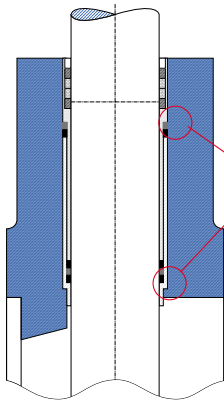

Zwick Armaturen has designed a zero leakage bushing (patent pending) that will assure no line media will migrate into the bushing cavity. This design has been proven in the severest of applications where other designs have failed due to fouling or galling of the bushing and shaft.



The standard shaft sealing meets the requirements of the emission according to „TA Luft“.

The high tech construction meets the demands for firesafe (API and BS), for requirements „TA Luft“ and for tightness in both flow directions under full class conditions.



The series TRI-CON will be modified to meet the customers individual demands

We are able to offer outstanding technical support and service to meet your special valve requirements. Quick delivery, competitive pricing and full customer service are additional advantages of our company.



The Zwick Armaturen Company - In the Center of Europe.

Our quality is your benefit! According to this principle we do our utmost to satisfy your requests. Due to continuous development and research we guarantee that we are your partner now and for the future.

Considered Standards:

Calculation:

TRD 110; DIN 3840;
ASME SEC. VIII;
ASME SEC. III;
ANSI B31.1;
ANSI B31.3,
API 609.

Face to Face dimensions:

DIN 3202, ISO 5752,
MSS-SP-68, API 609

Marking:

DIN 3230, MSS SP-25

Flanged Connection

DIN 2501, ISO 7005,
PN 10,16,25,40,64,100,
ANSI B16.5,
CL 150-300-600,
API, MSS SP-44,
CL 150-300-600,

Testing:

Leakage rate according to
DIN 3202, table 1
API 607, BS 6755 Rate A,
API 598

Quality Insurance:

DIN/ISO 9001
EN 29001

BUTTERFLY VALVE WITH SUPERIOR OPERATING CHARACTERISTICS

With its triple eccentric design and metal-to-metal sealing, the TRI-CON series guarantees an ideal valve design.

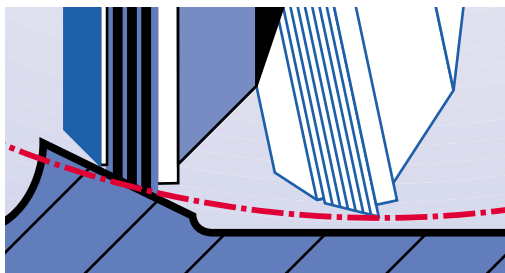

- true cone in cone sealing
- frictionless operating
- low torques
- constant closing angle on the total circumference

The operating characteristics and the tightness of the valve are not influenced by high differences in temperatures and pressure fluctuations because of the triple eccentric geometry and the valves' special features.

Maximum service life is achieved by eliminating any „rubbing“ between the laminated seal around the total circumference during seating which enables a frictionless opening and closing. This guarantees full tightness and low operating torques.



All metal laminated seal ring, for those high temperature or aggressive applications.

The bi-directional tightness and the frictionless closing are important advantages

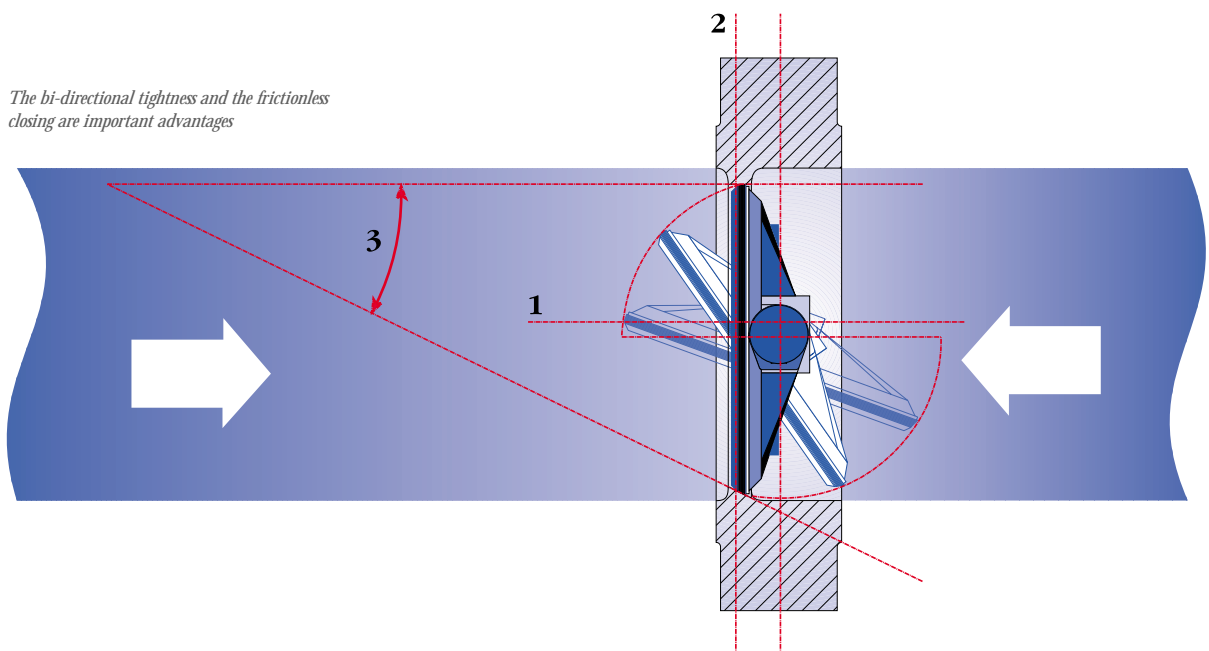

Range of applications:

The TRI-CON valve of the Zwick Armaturen company is applicable under severe service conditions where reliability and tightness is a main request.



Mineral Oil:

- On- and Off-Shore
- Refineries
- Storage and Transport
- Flammable Materials

Chemical Industry:

- Steam
- Hot Water
- Process
- Storage and Transport

Gas Industry:

- Oxygen
- Natural Gas
- Storage and Transport

Power Stations, District Heating:

- Steam
- Hot Water
- Process

Steel Industry:

- Waste Gases
- Cooling Water

Sugar Industry:

- Steam
- Hot Water
- Process

Pulp and Paper

- Steam
- Hot Water
- Process

Family of Body Styles:

The right housings for your application.



Model F:

Double Flange
DIN 3202/F4

- Simple mounting
- DN 100-1200
- PN10-100

Model S:

Buttweld S1

- No flange tightness problems
- DN80-1200
- PN10-100
- 4"-48"
- ANSI 150-600

Model D/I:

Double Flange
F16/ISO 5752

- World-wide standard
- DN80-1200
- PN10-100
- 3"-48"
- ANSI 150-600

Model B:

Double Flange
ANSI B16.10

- Gate valve replacement
- 3"-24"
- ANSI 150-600

Model A/L:

Lugged Type API
609/DIN K3

- Compact design
- DN65-900
- PN10-100
- 3"-36"
- ANSI 150-600

A PROVEN DESIGN WITH EXCELLENT CHARACTERISTICS

Special characteristics:

The self-centering disc

The construction guarantees the optimal position of the laminated seal against the seat. Jamming due to thermal expansion is eliminated.

The torque transmission with keys

The disc is keyed to the shaft not pinned, providing equal torque transmission and eliminating the danger of pins shearing off.

Ideal lamination and disc design

The strong disc with its elliptical supporting surface offers the best fixing of the lamination. The bubble tightness is given by the special machining of the lamination.

Supporting bearing bushings

The optimal position of the bearing reduces the bending of the shaft. This guarantees bi-directional tightness under maximum differential pressure.

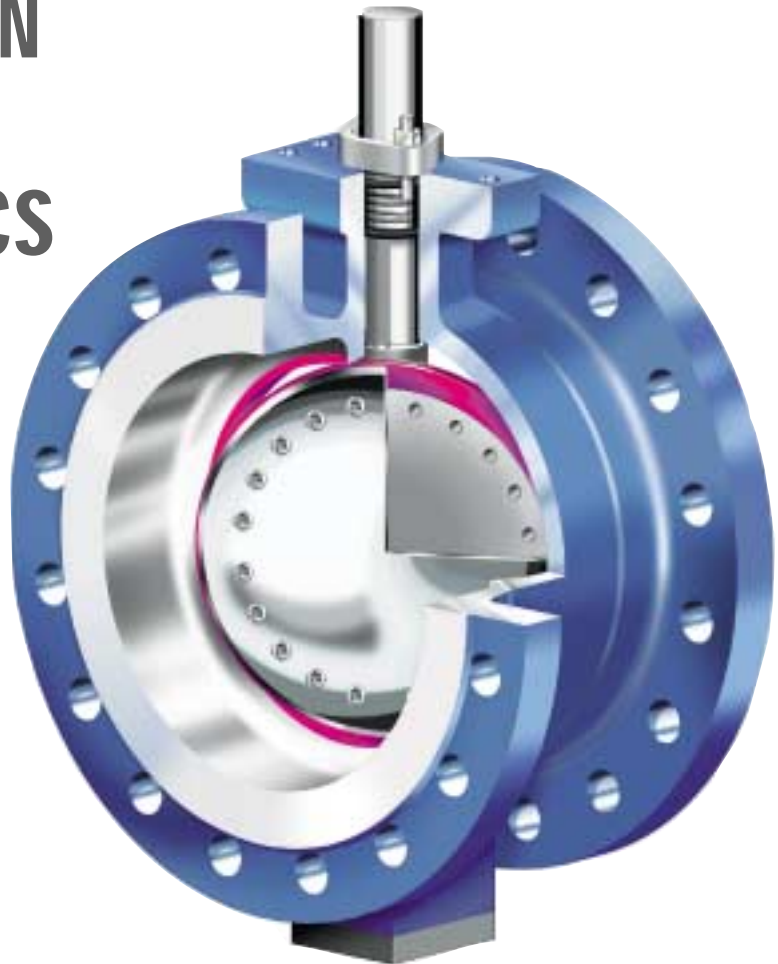

General characteristics:

- Triple eccentric design
- Metal seating
- Pressure classes according ANSI 150/300/600 and DIN PN 10/16/25/40/64/100
- Full bi-directional shut off according to API and DIN 3202, zero leakage
- Temperature range - 320°F up to + 1022°F (-196°C up to + 550°C) Additional requirements mutual agreement
- Size range 3" - 48" (DN 80-1200) Additional requirements mutual agreement
- Friction free opening and closing
- Vacuum tight
- Laminated seal and seat made of stainless steel
- Anti blow-out shaft API 609
- Steel casting, stainless steel, special alloys
- Fire-safe acc. to BS 6755 and API 607 4th ed. for both flow directions
- Special customer demand on request
- Fugitive emission control acc. to „TA-Luft“