

S-SERIES Temperature Switches

Switches for -60 through 640°F with Adjustable Set Points, Fixed or Adjustable Deadband and General Purpose, Watertight or Explosion-Proof Enclosures

Features:

- Set point repeatability, $\pm 1^{\circ}\text{F}$ ($1/2^{\circ}\text{C}$).
- All wiring terminals, adjustments and visual scales are accessible from the front of the switch.
- Choice of general purpose, watertight or explosion-proof enclosures.
- Choice of fixed or full-range adjustable deadband.
- Choice of single or two-stage units.
- Manual reset units available.
- Mounts in any position.
- Rugged and vibration resistant.
- Visual adjustment scales in $^{\circ}\text{F}$ and $^{\circ}\text{C}$.
- External adjusting nuts.
- Separate temperature, electrical and adjusting chambers.
- Direct mount (local) or capillary and bulb (remote) sensors.
- Temperature transducers available with copper or 316 stainless steel wetted material.
- Withstands high overrange temperatures.
- Mix and match switch and transducer components for increased stock flexibility or to change pressure ranges in field.

General Description:

ASCO S-Series temperature switches consist of a switch unit and a transducer unit. They can be ordered separately for customer stocking and/or field assembly or as a complete factory-assembled unit.

Switch

S-Series temperature switch units incorporate the unique ASCO TRI-POINT alternating fulcrum balance plate to control the operation of one or more electrical snap-action switches. The electrical snap-action switch together with the adjusting mechanism is a fully-tested, self-contained subassembly.

Transducer

The temperature transducer unit uses a vapor pressure principle where the internal pressure within the unit is generated by the vapor pressure of a chemical within a sealed system. Temperature transducers are available in two constructions, a direct mount or capillary and bulb construction. The direct mount unit includes a 1/2" NPT connection for direct mounting to the process. The capillary and bulb construction allows remote mounting



Standard Electrical Ratings

SA, SB, SC, SD and SE Series

- 15 Amp Res., 125 VAC
- 10 Amp Res., 250 VAC
- 1/8 HP, 125 VAC
- 1/4 HP, 250 VAC
- 1/2 Amp Res., 125 VDC
- 1/4 Amp Res., 250 VDC

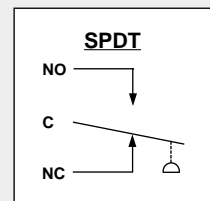

Standard Temperature Ratings

Ambient: -4°F (-20°C) to 140°F (60°C)

Fluid: See specification table on page 32 for rated overrange temperature.

from the process. The transducer unit (like the switch unit) is a fully-tested, self-contained subassembly.

Operation

Temperature sensed by the bulb creates an internal pressure within the transducer. This pressure is then converted into movement of the piston. This piston movement is then used to control the operation of the electrical snap-action switch in the switch unit.

Options (See pages 34-35)

Enclosures

ASCO TRI-POINT S-Series switches are available in three standard enclosures. All of these enclosed units are made in accordance with NEMA and UL standards.

General Purpose – Type 1. These enclosures are designed for indoor use to protect personnel from accidental contact with the equipment. S-Series general purpose switch units consist of a copper-free* aluminum die-cast body with a formed copper-free* aluminum cover; two 3/4" conduit hubs with one plug are provided.

Watertight – Type 4. Watertight and dust-tight enclosures are intended for use indoors and outdoors to protect the enclosed equipment against splashing or falling water, windblown dust and water, hose directed water, and severe external condensation. S-Series watertight switch units have a copper-free* aluminum die-cast body and a formed copper-free* aluminum cover with Buna "N" gaskets; two 3/4" conduit hubs with one plug are provided.

Explosion-Proof – Types 7 and 9. Type 7 enclosures are intended for use in locations defined by the National Electrical Code as Class I. Type 9 enclosures are intended for Class II locations.

Class I locations are those in which flammable gases are or may be present in the air in sufficient quantities to produce explosive or ignitable mixtures. Class I locations are classified by group letter, which defines particular atmospheres. Division 1 locations are areas where the hazardous concentration exists continuously, intermittently or periodically under normal operating conditions. Division 2 locations are those where the hazardous vapors are present only in case of accidental rupture or breakdown of equipment.

ASCO TRI-POINT explosion-proof enclosures with letter **B**, **C** or **D** in the fifth position are listed for Class I, Groups B, C, and D, Division 1. They are also suitable for the less stringent Division 2 environment.

Class II locations are those which are hazardous because of the presence of combustible dust. All ASCO TRI-POINT explosion-proof enclosures are listed for Groups E, F, and G locations.

The switch body and cover are die-cast copper-free* aluminum with a Buna "N" gasket. Two 3/4" conduit hubs with one plug are provided.

Dimensions (inches)

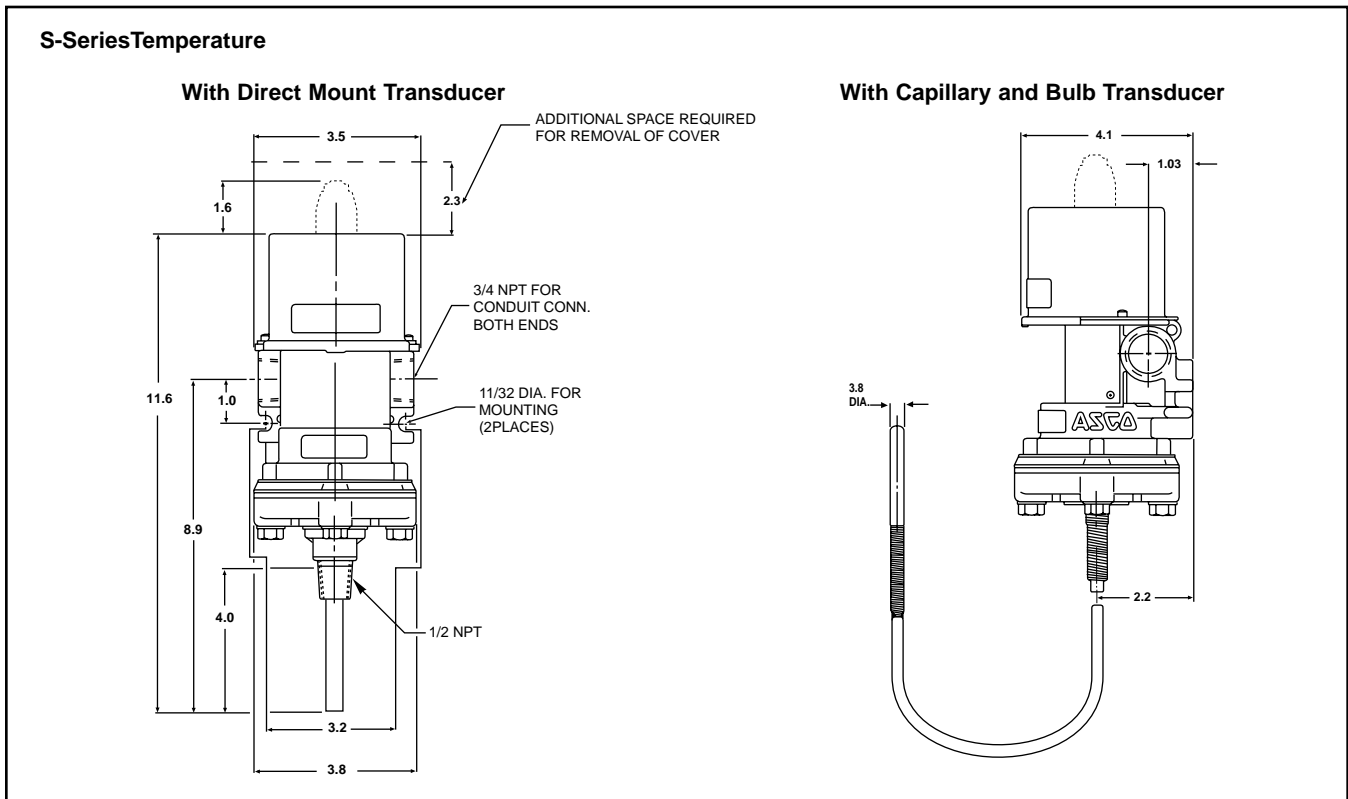

* Less than 0.6% copper.

S-SERIES Temperature Switches

How to Select and Order

ASCO S-Series switches consist of two components, the switch unit and the transducer unit.

How to Select

1. Select the adjustable operating range based on desired actuation temperature.
2. Check that rated overrange temperature is sufficient.
3. Read across and select the desired S-Series switch unit with the proper enclosure.
4. Continue across and select a matching transducer unit compatible with the fluid.

How to Order

Factory assembled – Simply order the switch and transducer unit by catalog number joined by a slash (/), e.g., SA10D/QA10A1.

Field assembled – Simply order the switch and transducer units separately by individual catalog number, e.g., one SA10D and one QA10A1.

Options – Add appropriate suffix for desired option (see pages 34-35).

Important Note: The third digit of each of the catalog numbers must be identical, e.g., SA 10D and QA 10A1.

Select S-Series temperature switch

SA Switch Unit

Single-Stage Adjustable Deadband units allow independent adjustment of the set and reset points over the full operating range of the switch. The minimum difference between set and reset points is the deadband listed below; the maximum difference is the full range of the switch.



General Purpose

SB, SD or SE Switch Unit

SB Switch Unit: Single-Stage Fixed Deadband units have an adjustable set point and a non-adjustable automatic reset point.
SD Switch Unit: Manual reset on decreasing temperature units operate automatically on increasing temperature and must be reset manually on decreasing temperature. (To order, change second digit to letter "D", e.g., S B 40D becomes S D 40D).
SE Switch Unit: Manual reset on increasing temperature units operate automatically on decreasing temperature and must be reset manually on increasing temperature. (To order, change second digit to letter "E", e.g., S B 40D becomes S E 40D).

Specifications				Adjustable Deadband			Fixed Deadband or Manual Reset				
Adjustable Operating Range (°F)	Rated Overage Temperature (°F)			Adjustable Deadband Maximum Full Scale	General Purpose Catalog No.	Watertight Enclosure Catalog No.	Explosion-Proof Catalog No.	Fixed Deadband At Mid-Range (°F) ①	General Purpose Catalog No.	Watertight Enclosure Catalog No.	Explosion-Proof Catalog No.
	Direct Mount	Capillary									
		Copper	SS								
-30 - 60	250	250	250	8	SA10D	SA11D	SA12D	3	SB10D	SB11D	SB12D
0 - 90	260	300	300	8	SA10D	SA11D	SA12D	3	SB10D	SB11D	SB12D
50 - 160	260	350	350	8	SA10D	SA11D	SA12D	3	SB10D	SB11D	SB12D
100 - 220	260	450	450	8	SA10D	SA11D	SA12D	3	SB10D	SB11D	SB12D
160 - 260	260	500	500	9	SA10D	SA11D	SA12D	3	SB10D	SB11D	SB12D
225 - 340	---	550	600	12	SA10D	SA11D	SA12D	6	SB10D	SB11D	SB12D
300 - 450	---	550	700	12	SA10D	SA11D	SA12D	6	SB10D	SB11D	SB12D
350 - 510	---	550	800	18	SA10D	SA11D	SA12D	7	SB10D	SB11D	SB12D
425 - 640	---	550	890	32	SA10D	SA11D	SA12D	20	SB10D	SB11D	SB12D

°C = (°F - 32) x 5/9

All switch units above are in stock for immediate delivery.

① Values shown are nominal.

SA, SB, SC, SD or SE unit below

SC Switch Unit

Two-Stage Fixed Deadband units consist of two separate snap-action switches, each with an independently adjustable set point and non-adjustable reset point. The difference between the set and reset points of each switch is the deadband listed below; the minimum difference between the set points of the two switches is the separation.



Explosion Proof

Two-Stage Fixed Deadband

Fixed Deadband At Mid-Range (°F) ①	Separation		General Purpose Catalog No.	Watertight Enclosure Catalog No.	Explosion-Proof Catalog No.
	Maximum Full Scale	Minimum At Mid-Range (°F) ①			
	4	8			
4	8	SC10D	SC11D	SC12D	
4	8	SC10D	SC11D	SC12D	
4	8	SC10D	SC11D	SC12D	
4	9	SC10D	SC11D	SC12D	
8	12	SC10D	SC11D	SC12D	
8	12	SC10D	SC11D	SC12D	
10	18	SC10D	SC11D	SC12D	
27	32	SC10D	SC11D	SC12D	

Select transducer unit below



Direct Mount
1/2" NPT



Capillary
and Bulb

Transducer Unit

The **temperature transducer** works on the vapor principle where the internal pressure within the system is generated by the vapor pressure of a chemical within a sealed system. The temperature sensed by the bulb is related uniquely to an internal pressure within the system. The pressure acts on a diaphragm/piston to create the force output from the transducer into the switch unit. Temperature transducers are available in two constructions. The direct mount (local) unit includes a 1/2" NPT connection for direct application to the process. The capillary and bulb-type construction allows for remote mounting from the process.

Transducer Units

Direct Mount		6' Capillary and Bulb		12' Capillary and Bulb	
Copper	316 SS	Copper (Armored Capillary)	316 SS (Plain Capillary)	Copper (Armored Capillary)	316 SS & (Plain Capillary)
Catalog No.	Catalog No.	Catalog No.	Catalog No.	Catalog No.	Catalog No.
QB10A1	QB10A4	QB11A1	QB11A4	QB11A1D	QB11A4D
QD10A1	QD10A4	QD11A1	QD11A4	QD11A1D	QD11A4D
QF10A1	QF10A4	QF11A1	QF11A4	QF11A1D	QF11A4D
QJ10A1	QJ10A4	QJ11A1	QJ11A4	QJ11A1D	QJ11A4D
QL10A1	QL10A4	QL11A1	QL11A4	QL11A1D	QL11A4D
---	---	QN11A1	QN11A4	QN11A1D	QN11A4D
---	---	QT11A1	QT11A4	QT11A1D	QT11A4D
---	---	QU11A1	QU11A4	QU11A1D	QU11A4D
---	---	---	QW11A4	---	QW11A4D

All switch units and transducer units above are in stock for immediate delivery.