

Series 2850

Pressure Relief Valves for Air, Steam, Vapor & Liquid Service

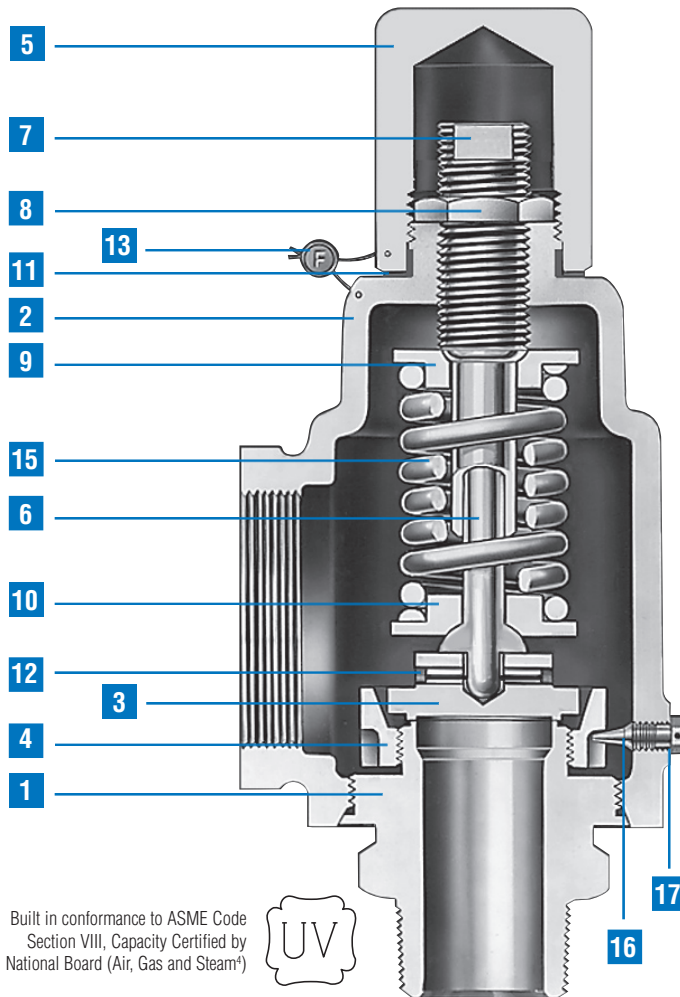

- Built in conformance to ASME Code Section VIII for Air, Steam, and Vapor Service.
- Set pressures to 300 psig.
- Stainless steel body and trim.



Built in conformance to ASME Code Section VIII, Capacity Certified by National Board (Air, Gas and Steam*)

Bill of Materials		
Item No.	Part Name	Material 2850 & 2852
1	Body	SA-479 Type 316 St. St. Or SA-351 Gr. CF8M St. St.
2	Bonnet	SA-216 Gr. WCB Carbon Steel
3	Disc	316 St. St.
4	Blow Down Ring	Stainless Steel
5	Cap, Plain Screwed	Carbon Steel
6	Stem	Stainless Steel
7	Spring Adj. Screw	Stainless Steel
8	Jam Nut	Stainless Steel
9	Spring Button (Upper)	Stainless Steel
10	Spring Button (Lower)	Stainless Steel
11	Cap Gasket	Stainless Steel
12	Grooved Pin	Stainless Steel
13	Wire Seal	Stainless Steel Wire/Lead Seal
14	Nameplate (not shown)	Stainless Steel
15	Spring	See Selection Table
16	Blow Down Ring Lock Screw	Stainless Steel
17	Blow Down Ring Lock Screw Gasket	316 St. St.

Selection Table									
(Connections: MNPT x FNPT)									
Type Number	Valve Size Inlet x Outlet	Maximum Set Pressure, psig ¹		Maximum Set Pressure, barg ¹		Maximum Back Pressures		Materials	
		-20°F to +400°F	+401°F to +750°F	-28.9°C to +204°C	+205°C to +399°C	psig @ 100°F	barg @ 37.8°C	Body / Bonnet	Spring ¹
285003-M20	3/4 x 1	300	300	20.7	20.7	50	3.45	316 St. St. / Carbon St.	316 St. St.
285004-M20	1 x 1 1/2								
285006-M20	1 1/2 x 2								

General Notes:

1. For high temperature range (+400°F to +750°F / +205°C to +399°C) change fourth digit of type number from "0" to "2". Example: 285003-M20 becomes 285203-M20. Spring changes to Chrome Alloy, rust proofed.
2. Type numbers shown designate valves with plain screwed caps. Test lever required for air, steam or hot water service (above 140°F / 60°C). For packed lever change the three digit type number suffix from "-M20" to "-M40". Example: 285003-M20 becomes 285003-M40.
3. For 1/2" x 1" size see 1890 Catalog.
4. Also suitable for liquid service where ASME Code certification is not required.



Capacity Tables: ASME PRESSURE VESSEL CODE (UV)

AIR 10% OVERPRESSURE Capacities in Standard Cubic Feet Per Minute at 60° F (Note 1)			
Set Pressure (psig)	3/4 x 1	1 x 1 1/2	1 1/2 x 2
15	93	160	375
20	108	185	433
30	136	234	547
40	168	288	674
50	199	342	800
60	231	396	926
70	263	450	1053
80	294	504	1179
90	326	558	1305
100	357	612	1432
150	515	882	2063
200	673	1152	2695
250	830	1423	3327
300	988	1693	3959

STEAM 10% OVERPRESSURE Capacities in Pounds Per Hour at Saturation Temperature (Note 1)			
Set Pressure (psig)	3/4 x 1	1 x 1 1/2	1 1/2 x 2
15	263	451	1055
20	303	520	1216
30	384	658	1539
40	473	810	1894
50	561	961	2249
60	650	1113	2604
70	738	1265	2959
80	827	1417	3313
90	916	1569	3668
100	1004	1720	4023
150	1448	2479	5798
200	1891	3238	7573
250	2334	3998	9348
300	2777	4757	11122

NON-CODE

WATER 25% OVERPRESSURE Capacities in U.S. Gallons Per Minute at 70° F			
Set Pressure (psig)	3/4 x 1	1 x 1 1/2	1 1/2 x 2
15	10.3	18.1	41.0
20	11.9	21.0	47.3
30	14.6	25.7	58.0
40	16.8	29.7	67.0
50	18.8	33.2	74.9
60	20.6	36.3	82.0
70	22.3	39.3	88.6
80	23.8	42.0	94.7
90	25.3	44.5	100
100	26.6	46.9	105
150	32.6	57.5	129
200	37.7	66.4	149
250	42.1	74.2	167
300	46.1	81.3	183

Notes:

1. Capacities for Air & Steam at 30 PSIG and below are based on 3 psi overpressure.

Actual Orifice Areas

Inlet Size	Vapor, Gas & Steam		Liquid	
	sq in	sq mm	sq in	sq mm
3/4"	0.240	155	0.109	70
1"	0.411	265	0.192	124
1 1/2"	0.961	620	0.433	279

Note: For sizing purposes, the coefficients of discharge K_d are 0.652 for air, gas, vapor and steam; 0.576 for liquids

Dimensions & Weights

Inlet Size	A (max) All Cap Constructions		B		C		Approx. Weight	
	in.	mm.	in.	mm.	in.	mm.	Lbs.	Kg.
3/4 x 1	8	203	1 11/16	43	2 5/8	67	3.5	1.6
1 x 1 1/2	9 1/16	112	1 15/16	29	3	76	5	2.3
1 1/2 x 2	11 15/16	252	2 7/8	73	3 11/16	94	11	5.0

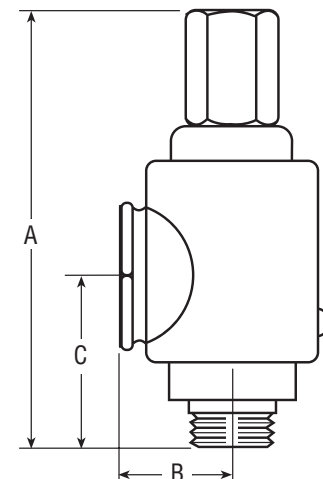

Farris Engineering Division of Curtiss-Wright Flow Control Corporation

10195 Brecksville Road, Brecksville, OH 44141 USA • Telephone: 440-838-7690 • Fax: 440-838-7699 • www.farrisengineering.com

Facilities: Brecksville, OH USA; Brantford, Ontario; Edmonton, Alberta, Canada; Kettering, Northants, UK; Delhi, India; Tianjin, China

Offices: worldwide. For a listing of our global sales network, visit our website at www.farrisengineering.com.

While this information is presented in good faith and believed to be accurate, Farris Engineering, Division of Curtiss-Wright Flow Control Corporation, does not guarantee satisfactory results from reliance on such information. Nothing contained herein is to be construed as a warranty or guarantee, expressed or implied, regarding the performance, merchantability, fitness or any other matter with respect to the products, nor as a recommendation to use any product or process in conflict with any patent. Farris Engineering, Division of Curtiss-Wright Flow Control Corporation, reserves the right, without notice, to alter or improve the designs or specifications of the products described herein.