

4195K Series Gauge Pressure Indicating Controllers

The 4195K Series gauge pressure indicating controllers (figure 1) show process pressure and set point on an easy-to-read process scale. The controllers, part of the versatile Wizard® family of pneumatic instrumentation, compare process pressure with an operator-adjusted set point. The 4195K Series controllers then deliver a pneumatic signal to a control element so that process pressure changes toward the set point. Controller types are available for proportional-only, proportional-plus-reset, proportional-plus-reset-plus-rate, and differential gap for on-off control. The 4195K Series controllers are used in industries where accurate pressure control

and process monitoring are required.

Unless otherwise noted, all NACE references are to NACE MR0175–2002.

Note

Neither Emerson, Emerson Process Management, nor any of their affiliated entities assumes responsibility for the selection, use, and maintenance of any product. Responsibility for the selection, use, and maintenance of any product remains with the purchaser and end-user.



W5663-1 / IL

YOKE-MOUNTED CONTROLLER

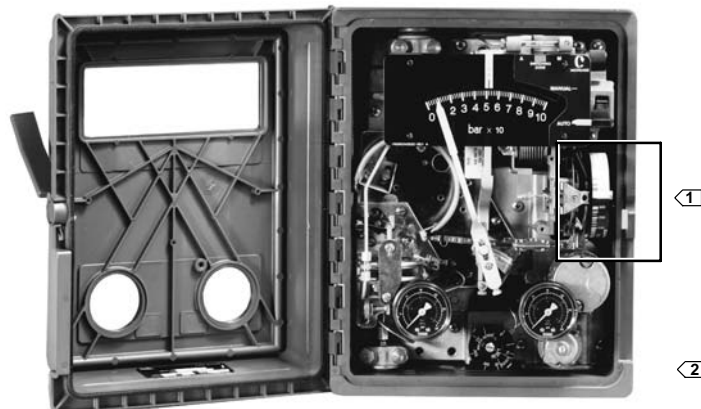

W5660-1 / IL

INTERIOR OF A FISHER® TYPE 4195KBME CONTROLLER

NOTES:

- 1 AN INTERNAL COVER PROTECTS THE PROPORTIONAL BAND ADJUSTMENT MECHANISM. IN THIS PHOTOGRAPH, THE COVER HAS BEEN REMOVED.
- 2 CONTROLLER COMPONENTS ARE INDICATED IN FIGURE 2.

Figure 1. 4195K Series Gauge Pressure Controllers



Specifications

Available Configurations

See table 1

Process Sensor Range (Input Signal)

Lower and Upper Range Limits: As shown in tables 2 and 5.

Maximum Allowable Pressure: As shown in tables 2 and 5.

Process Scale

Standard scale is matched to the range of the sensing element, with exception of receiver controllers. Optional scales available⁽¹⁾.

Process Connections

Standard: 1/4 NPT internal stainless steel (all input ranges)

Optional: 1/2 NPT external adaptors (see table 3)

Output Signal

Proportional, Proportional-Plus-Reset, or Proportional-Plus-Reset-Plus-Rate Range:

■ 0.2 to 1.0 bar (3 to 15 psig) or ■ 0.4 to 2.0 bar (6 to 30 psig)

Differential Gap Range: ■ 0 to 1.4 bar (0 to 20 psig) or ■ 0 to 2.4 bar (0 to 35 psig)

Action: Field-reversible between ■ direct (increasing sensed pressure increases output pressure), and ■ reverse (increasing sensed pressure decreases output pressure) action

Supply and Output Connections

1/4 NPT internal

Supply Pressure Requirements⁽²⁾

See table 4

Remote Set Point Pressures

■ 0.2 to 1.0 bar (3 to 15 psig) or ■ 0.4 to 2.0 bar (6 to 30 psig)

Construction Materials

See table 6

Controller Adjustments

Proportional Band: 5 to 500% of process scale span

Reset: Adjustable from 0.01 to more than 74 minutes per repeat (from 100 to less than 0.0135 repeats per minute)

Rate: Adjustable from 0 to 20 minutes

Differential Gap Controllers: Adjustable from 5 to 100% of process scale span

Set Point: Adjustable from 0 to 100% of the scale span

Controller Performance

Repeatability: 0.4% of output span

Dead Band: Less than 0.4% of process scale span

Typical Frequency Response: 1.5 hertz and 90 degree phase shift with 3.05 m (10 feet) of 6.4 mm (1/4-inch) tubing and 1639 cm³ (100 cubic inch) volume

Steady-State Air Consumption^(3,4)

0.2 to 1.0 Bar (3 to 15 Psig) Output: 0.10 normal m³/hr (3.5 scfh)

0.4 to 2.1 Bar (6 to 30 Psig) Output: 0.14 normal m³/hr (5.0 scfh)

Delivery Capacity⁽³⁾

0.2 to 1.0 Bar (3 to 15 Psig) Output: 5.9 normal m³/hr (240 scfh)

0.4 to 2.1 Bar (6 to 30 Psig) Output: 10.4 normal m³/hr (350 scfh)

Exhaust Capacity⁽³⁾

0.2 to 1.0 Bar (3 to 15 Psig) Output: 4.6 normal m³/hr (186 scfh)

0.4 to 2.1 Bar (6 to 30 Psig) Output: 7.0 normal m³/hr (295 scfh)

Operative Ambient Temperature Limits^(2,5)

-40 to 70°C (-40 to 160°F)

(continued)

Product Bulletin

34.5:4195K
November 2007

4195K Pressure Controllers

Specifications (continued)

Hazardous Area Classification

Complies with the requirements of ATEX Group II Category 2 Gas and Dust

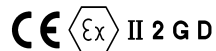

Housing

Designed to NEMA 3 (Weatherproof) and IEC 529 IP54 Specifications

Mounting

Controller can be mounted on ■ actuator, ■ panel, ■ wall, or ■ pipestand

Approximate Weight

4.5 kg (10 pounds)

NOTE: Specialized instrument terms are defined in ANSI/ISA Standard 51.1 – Process Instrument Terminology.

1. Consult your Emerson Process Management™ sales office for additional information.

2. The pressure/temperature limits in this document and any applicable code or standard should not be exceeded.

3. Normal m³/hr--Normal cubic meters per hour at 0°C, 1.01325 bar, absolute. Scfh--Standard cubic feet per hour at 60°F, 14.7 psia.

4. Without auto/manual station. With auto/manual station air consumption is 0.28 normal m³/hr (10.0 scfh).

5. Also use these temperatures for transportation and storage limits.

Table 1. Available Configurations

TYPE NUMBER(1)	MODES				OPTIONS		
	Proportional-Only	Proportional-Plus-Reset	Proportional-Plus-Reset-Plus-Rate	Differential Gap	Anti-Reset Windup (suffix letter F)	Remote Set Point (suffix letter M)	Internal Auto/Manual Station (suffix letter E)
4195KA	X	---	---	---	---	---	---
4195KAE	X	---	---	---	---	---	X
4195KAM	X	---	---	---	---	X	---
4195KAME	X	---	---	---	---	X	X
4195KB	---	X	---	---	---	---	---
4195KBE	---	X	---	---	---	---	X
4195KBF	---	X	---	---	X	---	---
4195KBFE	---	X	---	---	X	---	X
4195KBM	---	X	---	---	---	X	---
4195KBME	---	X	---	---	---	X	X
4195KBFM	---	X	---	---	X	X	---
4195KBFME	---	X	---	---	X	X	X
4195KC	---	---	X	---	---	---	---
4195KCE	---	---	X	---	---	---	X
4195KCF	---	---	X	---	X	---	---
4195KCFE	---	---	X	---	X	---	X
4195KCM	---	---	X	---	---	X	---
4195KCME	---	---	X	---	---	X	X
4195KCFM	---	---	X	---	X	X	---
4195KCFME	---	---	X	---	X	X	X
4195KS	---	---	---	X	---	---	---
4195KSE	---	---	---	X	---	---	X
4195KSM	---	---	---	X	---	X	---
4195KSME	---	---	---	X	---	X	X

1. Reverse-acting constructions are designated by the suffix letter R in the type number.

Features

- **Easy Maintenance**—Simple design allows fast, easy maintenance and minimal spare parts inventory.
- **Easy Adjustment**—Adjusting the set point, the zero and span of the process pointer, and switching between direct and reverse action are accomplished quickly and without special tools. Additionally, the set point and proportional band can be adjusted with no interaction between the two adjustments.
- **Application Versatility**—Either a Bourdon tube or capsular input element is available to control a wide range of positive pressures, vacuum pressures, or compound pressures.
- **Mounting Versatility**—A 4195K Series controller can be mounted directly on the actuator (figure 1) or it can mount on a pipestand, wall, or in a panel.
- **Vibration Resistance**—The simple design and low mass of internal parts allow a 4195K Series controller to withstand the vibration levels encountered in most plant environments.
- **High-Visibility Display**—Two red pointers on a 114 mm (4 1/2-inch) long, white-on-black scale show process pressure and deviation from set point at a glance. Two other gauges monitor supply pressure and output pressure.
- **Low Air Consumption**—The relay and nozzle design reduces steady-state air consumption to as low as 0.094 m³/hr (3.5 scfh).
- **Corrosion Resistance**—Tough, plastic housing resists such corrosive environments as chemical plants and the salt spray atmosphere on an offshore oil platform. Internal constructions are available to resist a corrosive supply pressure media.

Construction Features

Simplified Relay Maintenance

A clean-out wire provides a fast, easy means of cleaning the relay primary orifice during service.

Pressure Protection For The Case

A rubber plug in the plastic case pops out to relieve excessive pressure buildup inside the case.

Easy Direct/Reverse Switching

Controller action can be switched from direct to reverse or vice versa by simply loosening the screws on the proportional band cover and moving the cover out to rotate the proportional band knob to the desired action (see figure 2).

Easy Mode Conversion

Conversion from proportional to proportional-plus-reset control requires the addition of a reset valve and two pieces of tubing. Conversion from proportional to proportional-plus-reset-plus-rate control requires the addition of a reset/rate valve and three pieces of tubing. Conversion from proportional to differential gap for on/off control requires the addition of one piece of tubing.

Anti-Reset Windup

Anti-reset windup is available with proportional-plus-reset controllers. A relief valve may be installed to limit reset windup in either direction.

Remote Set Point

The capability to adjust the set point from a remote location is available as an option on the 4195K Series controllers.

Auto/Manual Capability

An optional internal auto/manual station permits smooth, bumpless transfer between automatic control and manual operation without disturbing the controller output. A positive-acting, two-position switch, showing either automatic or manual control mode, is clearly visible with the controller cover closed.

Product Bulletin

34.5:4195K
November 2007

4195K Pressure Controllers

Table 2. Process Sensor (Capsular Element) Pressure Ratings

CAPSULE MATERIAL	CAPSULAR STANDARD RANGES			SPAN ⁽¹⁾		OPERATING RANGE		OPERATING LIMIT ⁽²⁾
				Min	Max	Min	Max	
N09902 Nickel Alloy	Metric units	Positive pressure	0 to 150 mbar	100 mbar	160 mbar	-350 mbar	350 mbar	510 mbar
			0 to 400 mbar	350 mbar	700 mbar	-1 bar	1 bar	1.5 bar
			0 to 0.6 bar	0.35 bar	0.7 bar	-1 bar	1 bar	1.5 bar
			0.2 to 1 bar	0.4 bar	0.8 bar	-1 bar	1.4 bar	2 bar
			0 to 1 bar	0.5 bar	1 bar	-1 bar	1.4 bar	2 bar
			0 to 1.4 bar	0.7 bar	1.4 bar	-1 bar	1.7 bar	2.5 bar
		0 to 1.6 bar	1 bar	2 bar	-1 bar	2.4 bar	3.5 bar	
		0.4 to 2 bar	0.8 bar	1.6 bar	-1 bar	2 bar	3 bar	
		0 to 2 bar	1 bar	2 bar	-1 bar	2.4 bar	3.5 bar	
		Vacuum	-150 to 0 mbar	85 mbar	170 mbar	-350 mbar	350 mbar	510 mbar
			-340 to 0 mbar	170 mbar	340 mbar	-480 mbar	480 mbar	724 mbar
			-400 to 0 mbar	350 mbar	700 mbar	-1 bar	1 bar	1.5 bar
	-0.6 to 0 bar		0.35 bar	0.7 bar	-1 bar	1 bar	1.5 bar	
	-1 to 0 bar		0.5 bar	1 bar	-1 bar	1.4 bar	2 bar	
	Compound		-50 to 100 mbar	100 mbar	160 mbar	-350 mbar	350 mbar	510 mbar
		-175 to 175 mbar	175 mbar	350 mbar	-480 mbar	480 mbar	724 mbar	
		-150 to 250 mbar	350 mbar	700 mbar	-1 bar	1 bar	1.5 bar	
		-0.2 to 0.4 bar	0.35 bar	0.7 bar	-1 bar	1 bar	1.5 bar	
		-0.4 to 0.6 bar	0.5 bar	1 bar	-1 bar	1.4 bar	2 bar	
		-0.6 to 0.8 bar	0.7 bar	1.4 bar	-1 bar	1.7 bar	2.5 bar	
	-1 to 0.6 bar	1 bar	2 bar	-1 bar	2.4 bar	3.5 bar		
	-1 to 1 bar	1 bar	2 bar	-1 bar	2.4 bar	3.5 bar		
	U.S. units	Positive pressure	0 to 60 inch wc	40 inch wc	60 inch wc	-10 inch Hg	5 psig	7.5 psig
			0 to 5 psig	2.5 psig	5 psig	-14 inch Hg	7 psig	10.5 psig
0 to 10 psig			5 psig	10 psig	-30 inch Hg	15 psig	22.5 psig	
3 to 15 psig			6 psig	12 psig	-30 inch Hg	20 psig	30 psig	
0 to 15 psig			7.5 psig	15 psig	-30 inch Hg	20 psig	30 psig	
0 to 20 psig			10 psig	20 psig	-30 inch Hg	25 psig	37.5 psig	
6 to 30 psig		12 psig	24 psig	-30 inch Hg	30 psig	45 psig		
0 to 30 psig		15 psig	30 psig	-30 inch Hg	35 psig	52.5 psig		
Vacuum		-5 to 0 inch Hg	2.5 inch Hg	5 inch Hg	-10 inch Hg	5 psig	7.5 psig	
		-10 to 0 inch Hg	5 inch Hg	10 inch Hg	-14 inch Hg	7 psig	10.5 psig	
		-20 to 0 inch Hg	10 inch Hg	20 inch Hg	-30 inch Hg	15 psig	22.5 psig	
		-30 to 0 inch Hg	15 inch Hg	30 inch Hg	-30 inch Hg	20 psig	30 psig	
Compound	-30 to 30 inch wc	40 inch wc	60 inch wc	-10 inch Hg	5 psig	7.5 psig		
	-5 inch Hg to 2.5 psig	2.5 psig	5 psig	-14 inch Hg	7 psig	10.5 psig		
	-10 inch Hg to 5 psig	5 psig	10 psig	-30 inch Hg	15 psig	22.5 psig		
	-15 inch Hg to 7.5 psig	7.5 psig	15 psig	-30 inch Hg	20 psig	30 psig		
-20 inch Hg to 10 psig	10 psig	20 psig	-30 inch Hg	25 psig	37.5 psig			
-30 inch Hg to 15 psig	15 psig	30 psig	-30 inch Hg	35 psig	52.5 psig			

1. Minimum or maximum span or any span in between may be positioned anywhere within the operating range. For example, if a 0 to 350 mbar (0 to 5 psig) sensing element is used and the minimum span of 175 mbar (2.5 psig) is set, the process indication can be calibrated to a range of 340 mbar to 203 mbar (10 inch Hg to 6 inch Hg), 0 to 172 mbar (0 to 2.5 psig), 172 to 345 mbar (2.5 to 5 psig), 305 to 480 mbar (4.5 to 7 psig), or any value between minimum and maximum values of operating range.
2. Capsules with the travel stops set may be pressured to this value without permanent zero shift.

Table 3. Optional Process Connection Adaptors

BAR INPUT RANGE	PSIG INPUT RANGE	CONNECTION	
		Size	Material
Up to 0 to 400	Up to 0 to 5000	■ 1/2 NPT external or ■ 1/2 NPT internal	■ steel or ■ stainless steel
0 to 400 to 0 to 600	0 to 5000 to 0 to 10,000	1/2 NPT internal	stainless steel
0 to 400 to 0 to 600	0 to 5000 to 0 to 10,000	1/2 NPT external	stainless steel

Table 4. Supply Pressure Data

Output Signal Range		Normal Operating Supply Pressure ⁽¹⁾	Maximum Pressure Limit ⁽²⁾
Bar	0.2 to 1.0 or 0 and 1.4 (diff gap)	1.4	2.8
	0.4 to 2.1 or 0 and 2.4 (diff gap)	2.4	2.8
Psig	3 to 15 or 0 and 20 (diff gap)	20	40
	6 to 30 or 0 and 35 (diff gap)	35	40

1. If this pressure is exceeded, control stability may be impaired.
2. If this pressure is exceeded, damage to controller components may result.

Table 5. Process Sensor (Bourdon Tube) Pressure Ratings and Materials

BOURDON TUBES		SPAN ⁽¹⁾		OPERATING RANGE ⁽²⁾		OPERATING LIMITS ⁽⁴⁾	STANDARD MATERIAL	
		Minimum	Maximum	Minimum	Maximum ⁽³⁾			
Bar								
Metric units	0 to 1.6	1	2	-1	3	3.3	S31600 (316 stainless steel)	
	0 to 2.5	2	4	-1	6	6.6		
	0 to 4	2	4	-1	6	6.6		
	0 to 6	3.5	7	-1	10	11		
	0 to 10	7	14	-1	20	22		
	0 to 25	20	40	0	60	66		
	0 to 40	20	40	0	60	66		
	0 to 60	55	70	0	90	103		
	0 to 100	76	100	0	135	155		
	0 to 160	160	200	0	270	310		
		Psig	Psig	Psig	In. Hg	Psig	Psig	STANDARD MATERIAL
U.S. units	0 to 30	15	30	-30	42	48	S31600 (316 stainless steel)	
	0 to 60	30	60	-30	84	96		
	0 to 100	50	100	-30	140	160		
	0 to 200	100	200	-30	280	320		
	0 to 300	150	300	-30	420	480		
	0 to 600	300	600	0	840	960		
	0 to 1000	750	1000	0	1300	1500		
	0 to 1500	1100	1500	0	1950	2250		
	0 to 3000	2200	3000	0	3900	4500		
	0 to 5000	3700	5000	0	6000	7000		

1. Minimum or maximum span or any span in between may be positioned anywhere within the operating range. For example, if a 0 to 2 bar (0 to 30 psig) sensing element is used and the minimum span of 1 bar (15 psig) is set, the process indication can be calibrated to a range of 1 to 0 bar (30 in. Hg to 0 psig), 0 to 1 bar (0 to 15 psig), 1 to 2 bar (15 to 30 psig), 2 to 3 bar (27 to 42 psig) or any value between minimum and maximum values of operating range.
2. Travel stops should be used when the maximum or minimum process pressure will be 5% over or under the calibrated range. For example, a 0 to 2 bar (0 to 30 psig) sensing element is calibrated for 0.7 to 2 bar (10 to 30 psig), the desired range. The minimum expected pressure is 0 psig and the maximum expected pressure is 2.8 bar (40 psig). Travel stops must be used to prevent excessive overtravel and undertravel since the maximum allowable overpressure and underpressure is higher than 5% of the 1.4 bar (20 psig) span which is ±70 mbar (1 psig).
3. Bourdon tube without travel stops may be pressured to this value without permanent zero shift.
4. Bourdon tube with travel stops set may be pressured to this value without permanent zero shift.

Principle of Operation

Refer to the schematic diagrams in figures 3, 4, and 5. Refer to table 1 for a complete description of type number suffixes.

Proportional-Only Controllers (4195KA Series)

The input element is connected to the process pointer and to the flapper by connecting links. As the process pressure increases (in a direct-acting controller), the flapper moves toward the nozzle, restricting flow through the nozzle and increasing nozzle pressure. When this occurs, relay action increases the output pressure (delivery) of the controller. Output pressure is fed back to the proportional bellows. The action of the proportional bellows counteracts the flapper movement that resulted from the process pressure change and backs the flapper away from the nozzle until equilibrium is reached.

The set point adjustment changes the proximity of the nozzle and flapper as does a change in process pressure except that when the set point is changed, the nozzle moves with respect to the flapper.

The proportional band adjustment knob positions the nozzle on the flapper. Increasing (widening) the proportional band moves the nozzle to a position on the flapper where less input and more feedback motion occurs, which decreases the gain of the controller.

Decreasing (narrowing) the proportional band moves the nozzle toward a position where more input and less feedback motion occurs, which increases the gain. The controller action is changed from direct to reverse by turning the proportional band adjustment knob to position the nozzle on the flapper quadrant to a point where the direction of the flapper motion versus input motion is reversed (see flapper detail in figure 3). With the controller in the reverse-acting mode, an increase in process pressure causes a decrease in output pressure.

Proportional-Plus-Reset and Proportional-Plus-Reset-Plus-Rate Controllers (4195KB and KC Series)

The operation of proportional-plus-reset controllers (4195KB Series) is similar to that of proportional-only controllers (described above). However, in 4195KB Series controllers, output pressure is fed back to the reset bellows as well as to the proportional bellows. In operation, proportional-plus-reset controllers minimize the offset between the process pressure and set point.

As the process pressure increases (in a direct-acting controller), the flapper moves toward the nozzle, restricting flow through the nozzle and increasing nozzle pressure. When this occurs, relay action increases the output pressure (delivery) of the controller. Output pressure is fed back to the proportional bellows and to the reset bellows.

The action of the proportional bellows quickly counteracts the flapper movement that resulted from the process pressure change and backs the flapper away from the nozzle. Pressure in the reset bellows opposes the action of the proportional bellows and slowly moves the flapper closer to the nozzle. Thus, when the process pressure changes, proportional action temporarily reduces the gain of the controller for improved stability. The process pressure then slowly returns to set point, as pressure in both bellows equalizes via the reset action.

The set point adjustment changes the proximity of the nozzle and flapper as does a change in process pressure. However, when the set point changes, the nozzle moves with respect to the flapper.

The proportional band adjustment knob positions the nozzle on the flapper. Increasing (widening) the proportional band moves the nozzle to a position on the flapper where less input and more feedback motion occurs, which decreases the gain of the controller. Decreasing (narrowing) the proportional band moves the nozzle toward a position where more input and less feedback motion occurs, which increases the gain.

The controller action is changed from direct to reverse by turning the proportional band adjustment knob to position the nozzle on the flapper quadrant to a point where the direction of the flapper motion versus input motion is reversed. With the controller

in the reverse-acting mode, an increase in process pressure causes a decrease in output pressure.

A 4195KC Series controller also has a rate valve, which is an adjustable restriction that momentarily increases the controller gain to accelerate the corrective action for slow pressure systems. A proportional-plus-reset-plus-rate controller responds to a change in process pressure as follows: First, the rate action delays the proportional action just long enough to allow the controller to respond to the change quickly with high gain, but not long enough for the high gain to cause instability. Then, the low gain provided by the proportional action keeps the system stable. Finally, reset action slowly increases the gain and returns the process pressure toward the set point.

Differential Gap (For On-Off Control) Controllers (4195KS Series)

The operation of differential gap controllers (4195KS Series) is similar to that of proportional-only controllers (described above). However, in 4195KS Series controllers, as the process pressure increases, approaching the upper switching point, the flapper moves toward the nozzle (in a direct-acting controller). This movement restricts the flow through the nozzle and increases nozzle pressure. When this occurs, relay action increases the output pressure (delivery) of the controller. Output pressure is fed back to the positive feedback bellows. The action of the positive feedback bellows moves the flapper closer to the nozzle, increasing nozzle pressure, which in turn, increases the relay output. Output pressure to the final control element switches to full supply pressure.

As the process pressure decreases, approaching the lower switching point, the flapper moves away from the nozzle (in a direct-acting controller) reducing nozzle pressure. Through relay action, pressure to the positive feedback bellows is reduced, moving the flapper farther away from the nozzle, and further reducing nozzle pressure. Output pressure to the final control element switches to zero.

The set point adjustment changes the proximity of the nozzle and flapper as does a change in process pressure except that, when the set point is changed, the nozzle moves with respect to the flapper. The set point adjustment moves both the upper and lower switching points.

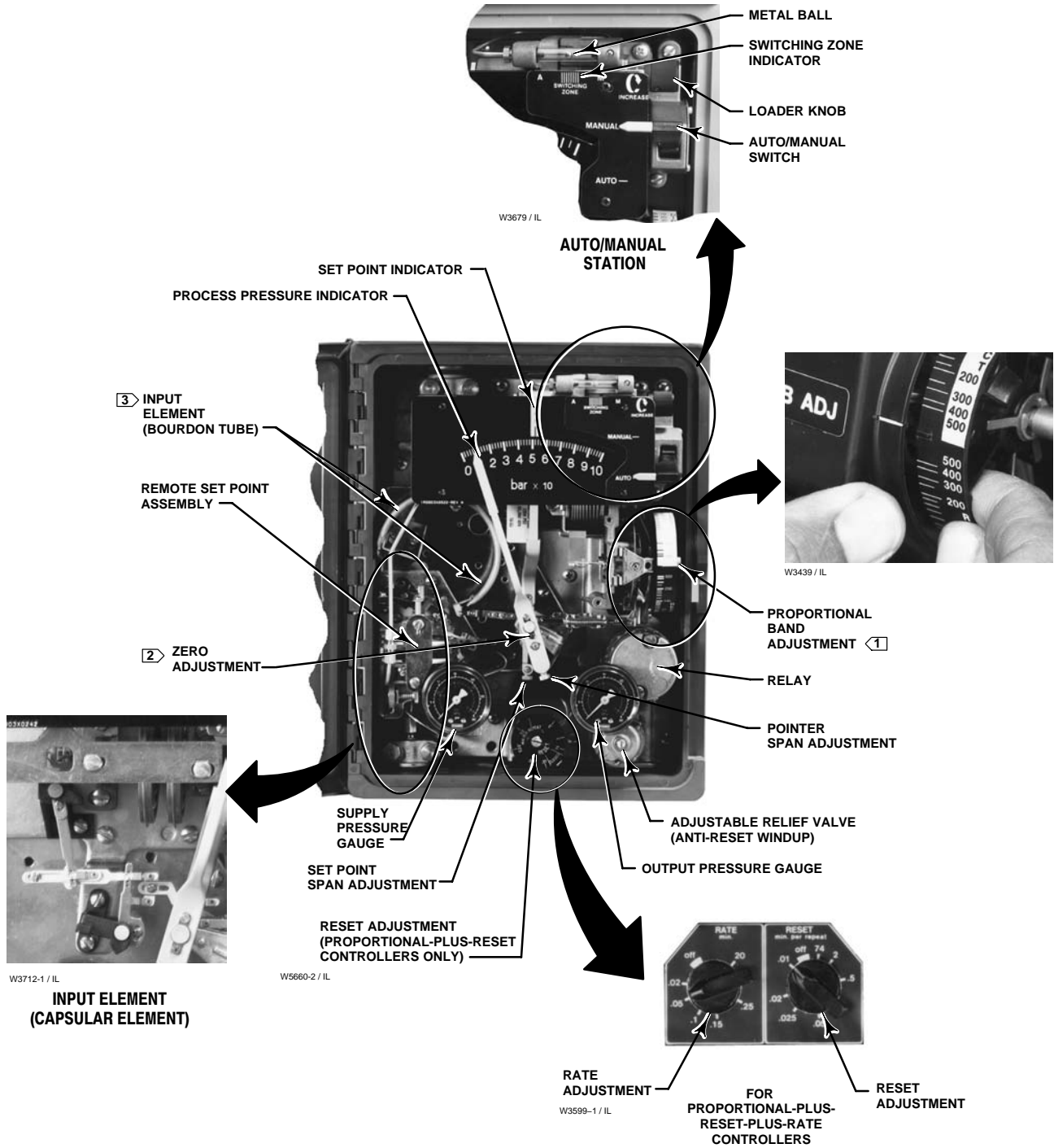

NOTES:
 [1] WHITE PORTION OF PROPORTIONAL BAND ADJUSTMENT ENABLES DIRECT CONTROLLER ACTION; BLACK PORTION ENABLES REVERSE CONTROLLER ACTION.
 [2] FOR THE PROCESS POINTER.
 [3] INPUT ELEMENT IS A BOURDON TUBE OR A CAPSULAR ELEMENT (AS SHOWN IN INSET) DEPENDING ON INPUT RANGE. SEE TABLES 2 AND 5.

Figure 2. Controller Construction Details

Table 6. Construction Materials

Part	Standard Material	Optional Material
Case and cover	Polyester plastic	---
Exterior tubing	Copper	■ stainless steel, ■ polyethylene
Exterior fittings	C36000 (brass)	■ stainless steel, ■ polyethylene
Interior tubing	Copper	S30400 (304 stainless steel)
Bourdon tube ⁽¹⁾	S31600 (316 stainless steel)	■ N09902 nickel alloy, ■ N05500 nickel alloy (for NACE applications)
Nozzle	S30300 (303 stainless steel)	---
Flapper	S31600 (316 stainless steel)	---
Relay springs	■ S30200 (302 stainless steel), ■ steel	---
Relay O-rings	Nitrile	---
Relay diaphragms	Nitrile	---
Other relay metal parts	■ Aluminum, ■ stainless steel	---
Feedback bellows assembly	C51000 (bronze)	S32100 (321 stainless steel)
Supply, output gauges	Brass (wetted parts only)	stainless steel (wetted parts only)
Remote set point element	■ N09902 nickel alloy ■ S30300 (303 stainless steel)	---
Capsular input element	N09902 nickel alloy	S31600 (316 stainless steel)

1. Consult your Emerson Process Management sales office for information on other materials.

The proportional band knob positions the nozzle on the flapper. Increasing (widening) the proportional band moves the nozzle away from the input connection. When the proportional band adjustment moves the nozzle across the feedback connection, the controller action changes between direct and reverse. On a direct-acting controller, changing the proportional band adjustment will widen or narrow the differential gap between the two switching points. This is accomplished by moving the position of the lower switching point. On a reverse-acting controller, changing the proportional band adjustment will widen or narrow the differential gap between the two switching points by moving the position of the upper switching point.

Remote Set Point Option (Suffix Letter M)

The capability to adjust the controller set point from a remote location is available for all 4195KA Series controllers. With this option, a control pressure is applied to the capsular element within the remote set point assembly. The expansion and contraction of the capsule moves the set point adjustment via connecting linkage. Increasing the control pressure to the capsule increases the set point setting, and decreasing the control pressure reduces the set point setting. This option is designated by the letter M in the type number.

Auto/Manual Station Option (Suffix Letter E)

A controller with the auto/manual option (designated by the letter E in the type number) has piping on the output side of the relay as shown in figure 4. Supply pressure to the relay is also applied to the manual loader. The manual loader, functioning as a regulator, applies pressure to one side of the plastic tube and to the auto/manual switch. Output pressure from the relay registers on the other side of the plastic tube as well as in the auto/manual switch.

When the auto/manual switch is in the MANUAL position, the manual loader output is channeled through the auto/manual switch and becomes the controller output. When the auto/manual switch is in the AUTO position, the relay output is channeled through the switch to become the controller output.

Before the auto/manual switch is operated, the relay output must equal the manual loader output to avoid bumping the process. Adjusting the set point varies the pressure on the left-hand side of the plastic tube. Adjusting the manual loader knob varies the pressure on the right-hand side of the plastic tube. When the pressures are equal, the metal ball is centered in the tube and is held in place by a small magnet. Pressure imbalance forces the ball to one end of the tube where it forms a seal, blocking air flow through the tube.

4195K Pressure Controllers

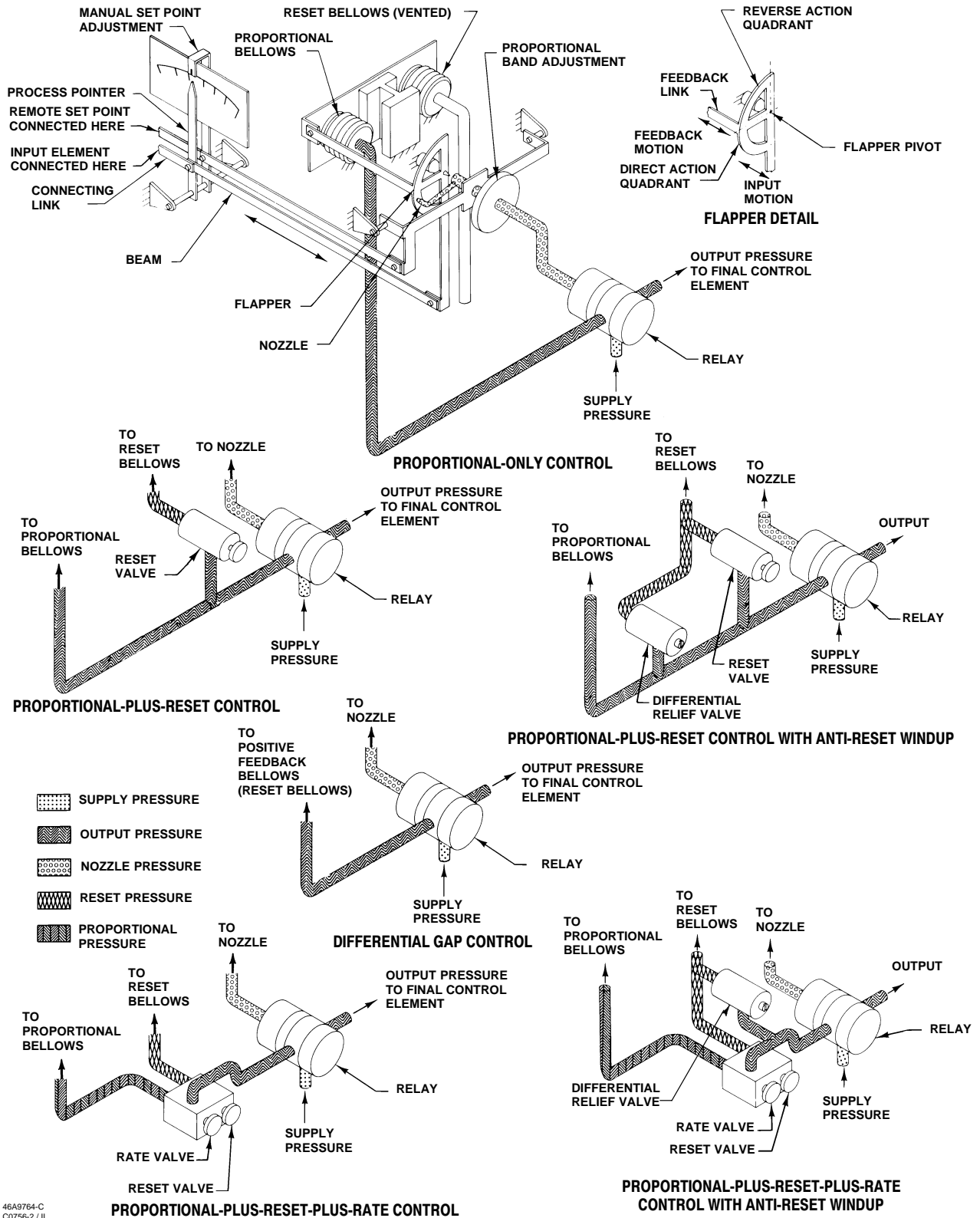

Figure 3. Schematic of 4195K Series Controllers

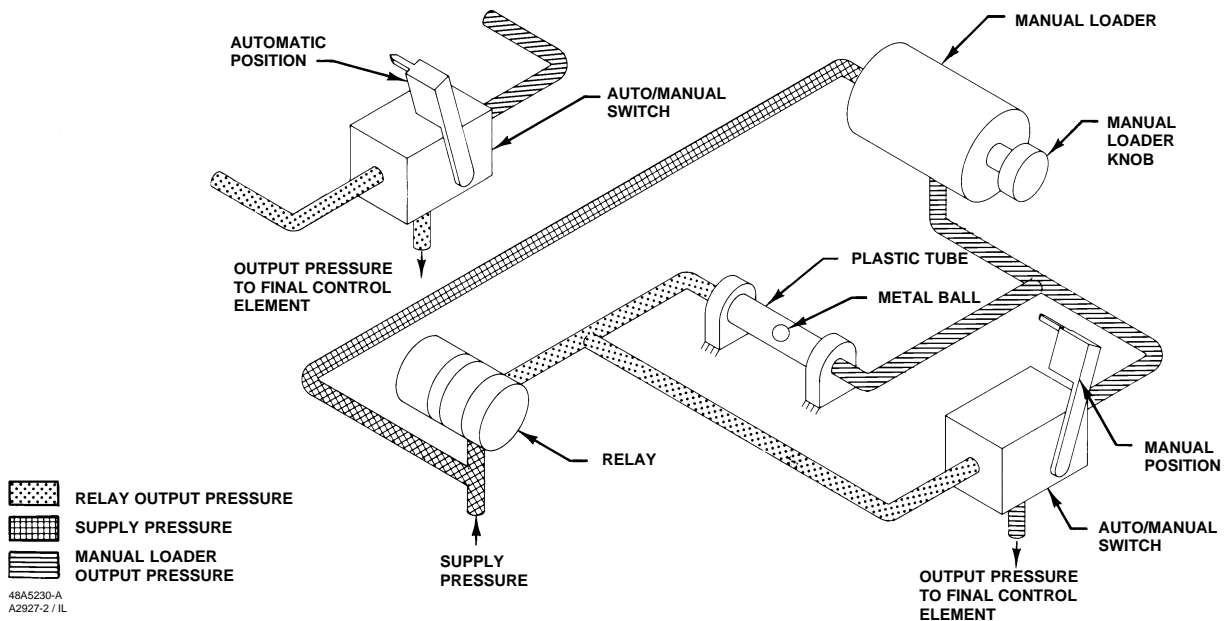

Figure 4. Schematic of Auto/Manual Station

Anti-Reset Windup Option (Suffix Letter F)

Anti-reset windup is available for all 4195KB and KC Series controllers and is designated by the letter F in the type number. The differential relief valve operates when the difference between the proportional bellows pressure and the reset bellows pressure reaches a predetermined value. Anti-reset windup reduces overshoot of the process pressure that can result from a large or prolonged deviation from set point.

External Feedback Option

External feedback is available for all 4195KB Series controllers. Controllers with this option have an external connection on the bottom of the controller case (see figure 7). This connection breaks the positive feedback (reset) loop inside the controller and brings it outside (see figure 5).

The connection allows the positive feedback loops of two controllers (primary and secondary) to be tied together when the controllers are used in an override application. When connected, the secondary controller reset pressure tracks the primary controller output pressure, minimizing reset windup in the secondary controller.

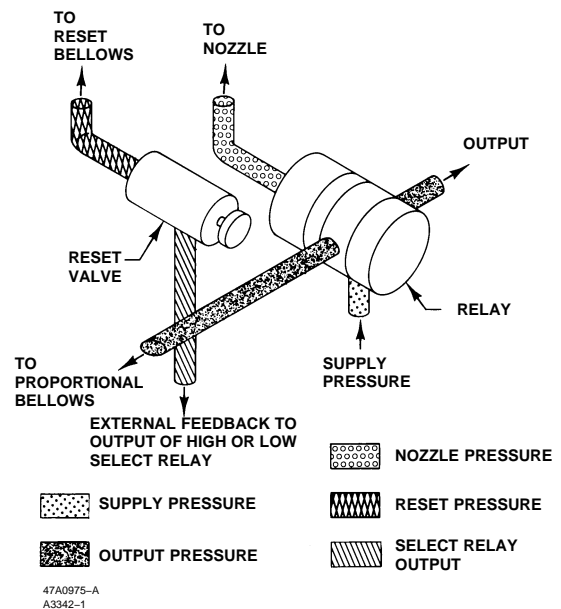

Figure 5. Schematic of External Feedback Option

Installation

The 4195K Series gauge pressure controllers can be shipped alone for a separate installation or for installation on a control valve actuator. The controllers can also be mounted on a pipe stand, on a wall, or in a panel. When a controller is mounted on an actuator and a positioner is not used, the controller will usually be opposite the supply regulator as shown in figure 6. If a positioner is used, the supply regulator can be mounted on the actuator casing.

The controller must be installed so the vent points down. Basic controller dimensions are shown in figure 7. Dimensions for specific mounting configurations are shown in figure 8.

Ordering Information

When ordering a 4195K Series controller, specify:

- **Application**

1. Description of the service, such as throttling or on-off
2. Pressure range, composition, and temperature of process fluid
3. Ambient temperature

- **Construction**

Refer to the specifications and to the Construction Features section. Carefully review each specification and feature, indicating your choice whenever a selection is to be made. Refer to table 1 for type numbers; add an R to any type number if reverse action is desired.

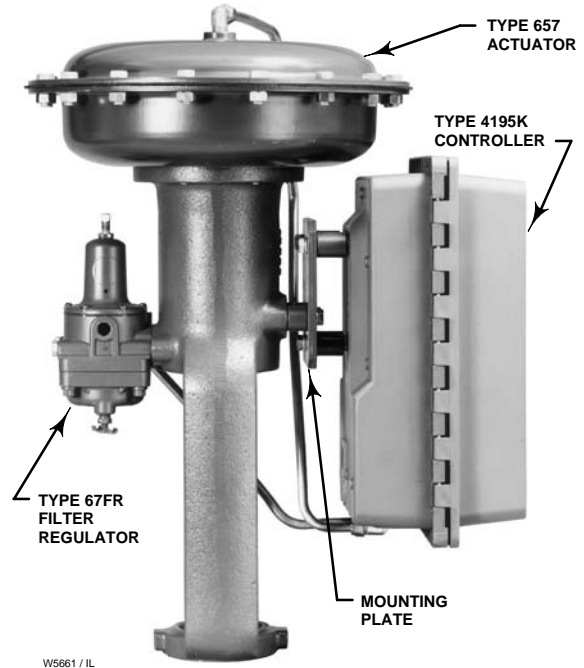

Figure 6. Typical Yoke Mounting

Note

Neither Emerson, Emerson Process Management, nor any of their affiliated entities assumes responsibility for the selection, use, and maintenance of any product. Responsibility for the selection, use, and maintenance of any product remains with the purchaser and end-user.

Product Bulletin

34.5:4195K
November 2007

4195K Pressure Controllers

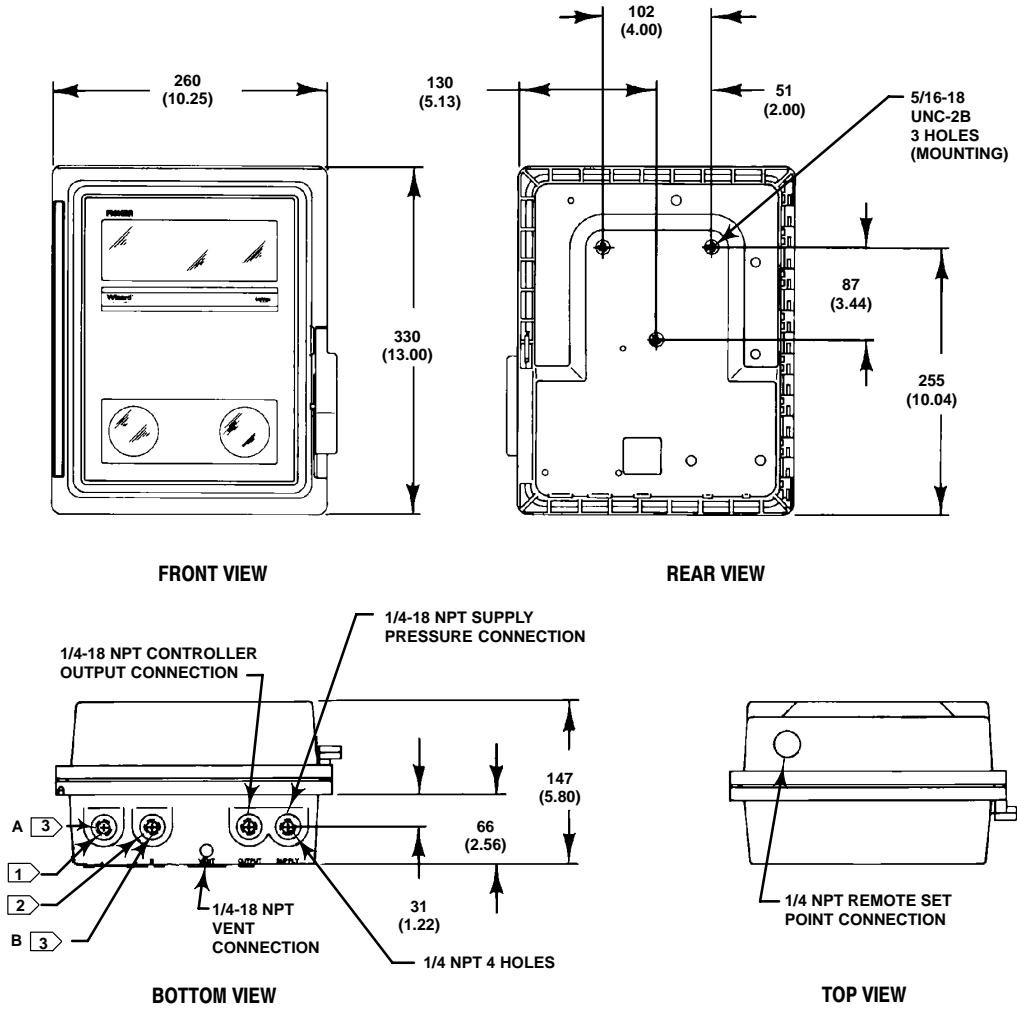

NOTES:

- 1 1/4-18 NPT PROCESS CONNECTION (MARKED A) FOR ALL BOURDON TUBE CONTROLLERS AND FOR THOSE CAPSULAR ELEMENT CONTROLLERS USED IN VACUUM PRESSURE APPLICATIONS.
- 2 1/4-18 NPT PROCESS CONNECTION (MARKED B) FOR CAPSULAR ELEMENT CONTROLLERS USED IN POSITIVE AND COMPOUND PRESSURE APPLICATIONS.
- 3 FOR THE EXTERNAL FEEDBACK CONNECTIONS (4195KB CONTROLLERS ONLY), EITHER THE A OR B CONNECTION IS USED, DEPENDING ON THE LOCATION OF THE PROCESS CONNECTION.

mm
(INCH)

46A9765-A
A2892-4 / IL

Figure 7. Controller Dimensions and Connections

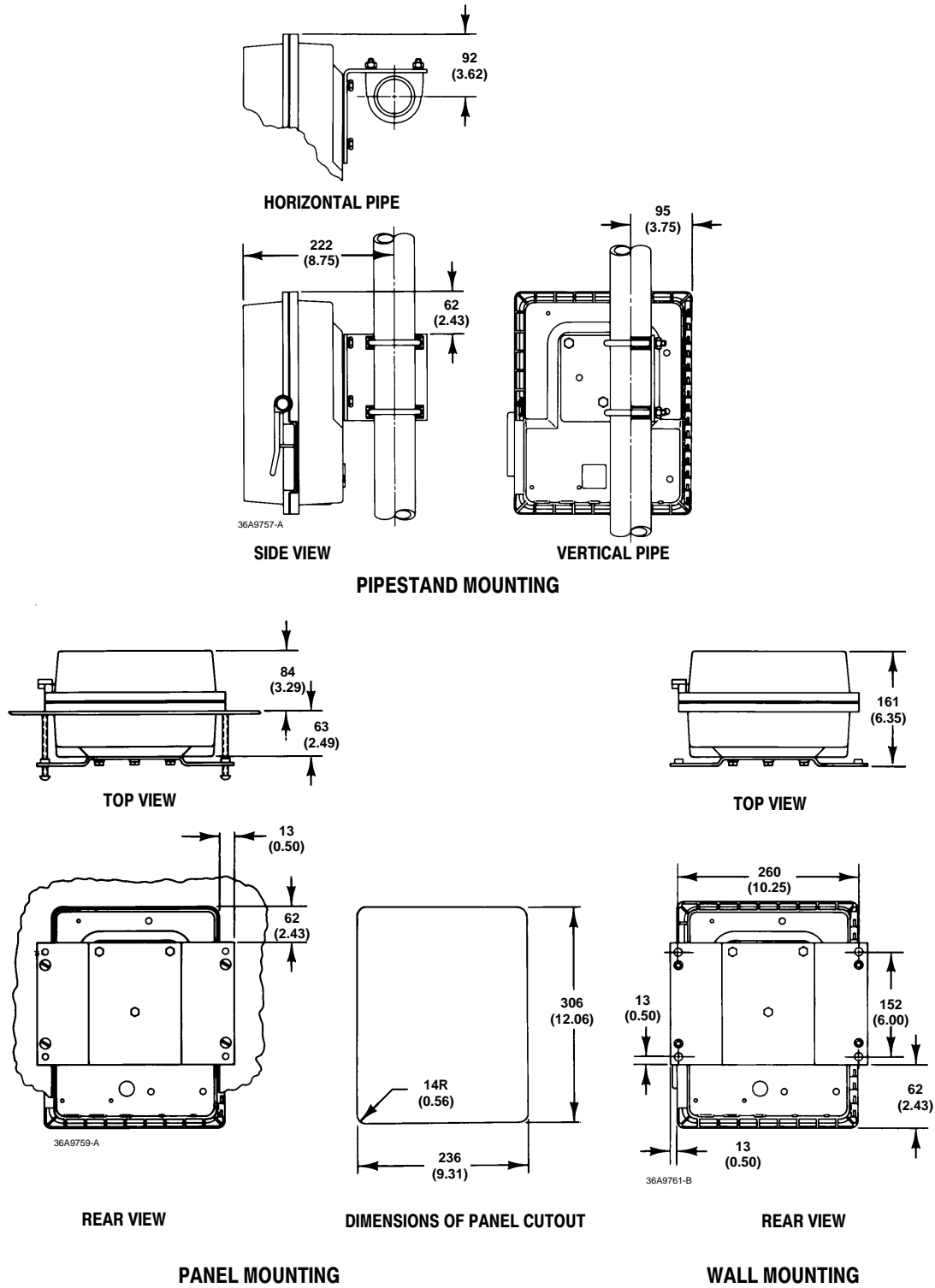

mm
(INCH)

Figure 8. Mounting Dimensions

Product Bulletin

34.5:4195K
November 2007

4195K Pressure Controllers

4195K Pressure Controllers

Product Bulletin

34.5:4195K
November 2007

Wizard and Fisher are marks owned by Fisher Controls International LLC, a member of the Emerson Process Management business division of Emerson Electric Co. Emerson Process Management, Emerson, and the Emerson logo are trademarks and service marks of Emerson Electric Co. All other marks are the property of their respective owners.

The contents of this publication are presented for informational purposes only, and while every effort has been made to ensure their accuracy, they are not to be construed as warranties or guarantees, express or implied, regarding the products or services described herein or their use or applicability. We reserve the right to modify or improve the designs or specifications of such products at any time without notice.

Neither Emerson, Emerson Process Management, nor any of their affiliated entities assumes responsibility for the selection, use and maintenance of any product. Responsibility for the selection, use and maintenance of any product remains with the purchaser and end-user.

Emerson Process Management

Marshalltown, Iowa 50158 USA

Cernay 68700 France

Sao Paulo 05424 Brazil

Singapore 128461

www.Fisher.com

