

Fisher[®] RSS Lined Globe Valve

The Fisher RSS lined globe-style valve (figure 1) is a one-piece valve body which has pure-modified (reinforced) PTFE trim parts, push-down-to-close action, and positive shutoff. The sophisticated PTFE trim has replaced the previously used glass-filled or carbon-filled standard PTFE trim without any loss of mechanical or thermal properties and has improved the universal chemical resistance. This valve is for applications involving severely corrosive and toxic flowing media and is well-suited for pure media applications, as well. Within its temperature and pressure limitations, the RSS valve body may also be applied to most media. The RSS valve body provides an economical alternative to alloy valve bodies in a wide variety of applications.

Features

- **Fluid Compatibility**—The PFA (perfluoroalkoxy resin)-lined assembly provides corrosion protection by shielding metal parts from the process media, making it ideal for controlling severely corrosive media.
- **Permeating Service**—A heavy duty PTFE bellows with stainless steel support rings is standard for all services in the NPS 1 to 4 valve sizes. Compared to a standard bellows, the heavy duty bellows design has an enhanced resistance to permeation. This is due to a wall thickness of 2.5 mm (0.1 inch) and pressure retaining rings inside the bellows. This bellows features a modified PTFE material (TFM 1705) which provides additional permeation protection over the original heavy duty PTFE bellows.
- **Economy**—Because all metal parts are shielded from the process fluid, the use of expensive alloys is not necessary.



W9164

Figure 1. Fisher RSS Valve with 667 Actuator and FIELDVUE[®] DVC6000 Digital Valve Controller



RSS Valve

Contents

Features	1
Tables	
Valve Size, Port Diameter, Maximum Flow Coefficient, Travel, and Stem and Yoke Boss Diameter	2
Maximum Allowable Inlet Pressures and Temperatures for All CL150 and 300 Valves	2
Construction Materials	5
Dimensions and Weights	6
Coefficients	8
Specifications	7

density, and low permeability. Transfer molded PFA material is translucent. This allows for checking of the entire wall surface for pin holes and cracks in the material during the manufacturing process.

Greater safety under vacuum and high temperature service is achieved by dovetail anchorings which provide a mechanical bond, minimizing the possibility of detachment of the lining from the cast valve body.

- **Easy In-Line Maintenance**—The top entry design eases in-line maintenance. This design also minimizes the transfer of pipeline stress, which minimizes leakage both at the valve body joint and seat ring.

Features (continued)

- **Liner Integrity**—Lining thickness is a minimum of 5 millimeters at all areas where the valve is exposed to process flow. Transfer molding techniques provide for excellent consistency,

- **Long Life Bellows Seal**—The PTFE bellows seal is leak tight and, with proper use and maintenance, can have an expected life cycle exceeding 500,000 full stroke cycles.

Table 1. Valve Size, Port Diameter⁽¹⁾, Maximum Flow Coefficient, Travel, and Stem and Yoke Boss Diameter

VALVE SIZE	PORT DIAMETER		LIQUID FLOW COEFFICIENT (C _v) AT MAXIMUM TRAVEL ⁽²⁾	MAXIMUM VALVE PLUG TRAVEL		STEM DIAMETER		YOKE BOSS DIAMETER		
	NPS	mm		Inches	Heavy Duty Bellows with Support Rings		mm	Inches	mm	Inches
					mm	Inches				
1		8	0.3125	1.91	15	0.591	9.5	3/8	54	2-1/8
		15	0.5	3.57						
		20	0.75	8.41						
		25	1	11.5						
1-1/2		25	1	13.4	19.1	0.75				
		40	1.5	28.6						
2		30	1.1875	13.3						
		50	2	44.3						
3		50	2	43.3	28.6	1.125	12.7	1/2	71	2-13/16
		80	3.1875	94.1						
4		65	2.5	69.3						
		96	4	145						

1. Inch equivalents of these metric port diameters have been rounded to common imperial decimal diameters. Actual diameter of the 15 millimeter port diameter is 0.591 inches, the 40 millimeter port diameter is 1.575 inches, and the 96 millimeter port is 3.780 inches.
2. K_v = (0.865) (C_v)

Table 2. Maximum Allowable Inlet Pressures and Temperatures for All CL150 and 300 Valves

TEMPERATURE, °C	PRESSURE, BAR		TEMPERATURE, °F	PRESSURE, PSIG	
	Ductile Iron			Ductile Iron	
-29 to 38	19.7		-20 to 100	285	
93	17.9		200	260	
149	15.9		300	230	
180	14.8		360	215	

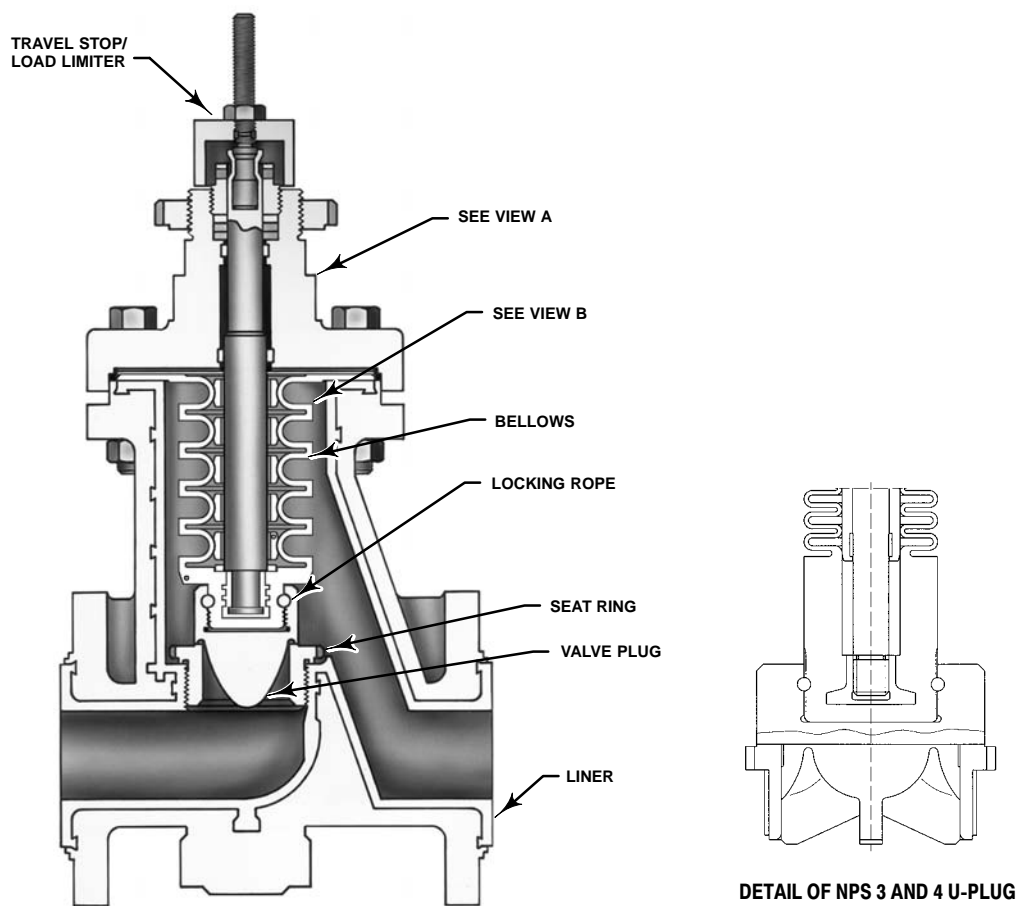

W4521-4HDB

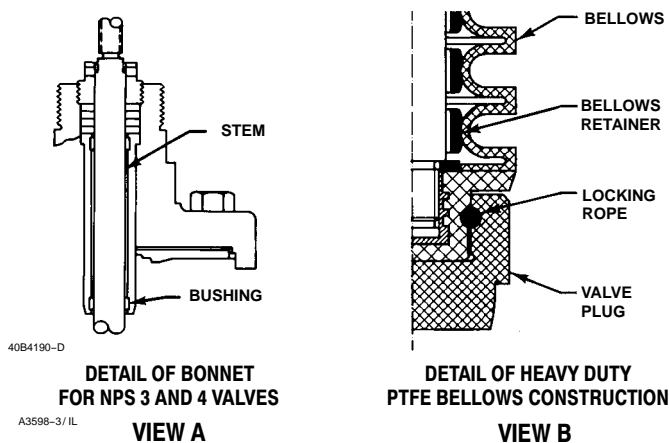

40B4190-D

A3598-3/IL

Figure 2. Fisher RSS Valve Details

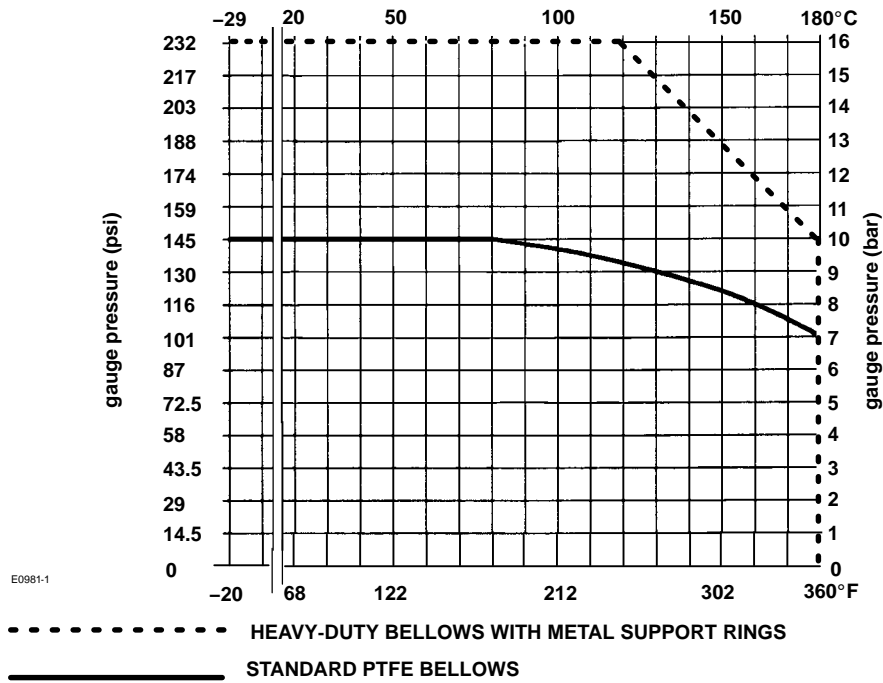

NOTE: THE LINER DOES NOT LIMIT THE DOWNSTREAM PRESSURE RATING IN POSITIVE PRESSURE SERVICES.

Figure 3. Downstream/Outlet Pressure Ratings (Positive Pressure Service)

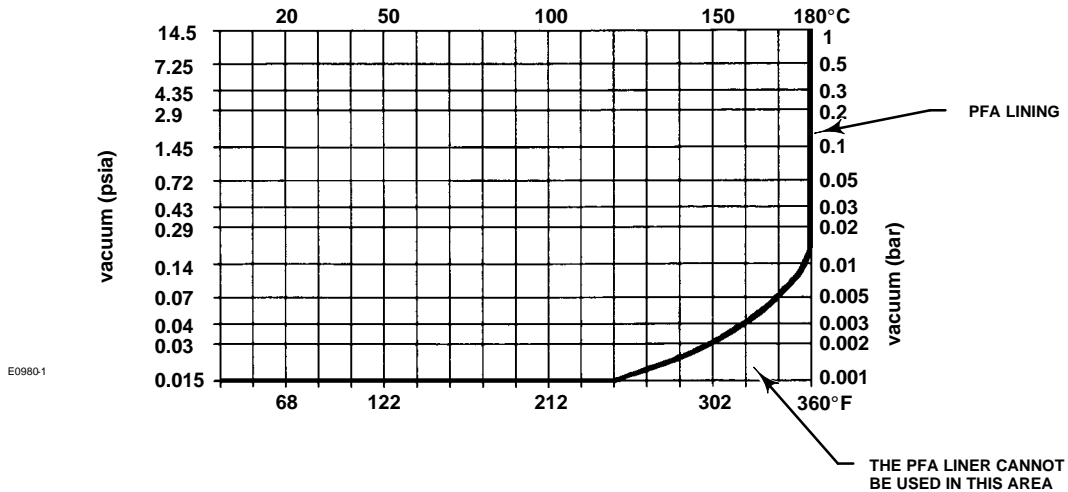

Figure 4. Downstream/Outlet Pressure Ratings (Vacuum Service)

Table 3. Construction Materials

Part	Standard Material
Valve Body	Ductile iron (ASTM A 395) with PFA ⁽¹⁾ liner
Bonnet	Ductile iron
Bellows	Heavy-duty PTFE (TFM1705) with 304L SST support rings
Valve plug and seat ring	Pure modified (reinforced) PTFE
Bonnet bushings	Carbon Graphite
Valve plug stem	Stainless steel
Body-to-bonnet bolting	Stainless steel
Packing	PTFE
Packing follower and packing box ring	Stainless steel
Travel stop	Stainless steel
Locking rope	PTFE
Bonnet O-ring	Fluorocarbon

1. Perfluoroalkoxy resin.

Table 4. ANSI/ISA CL150 Face-to-Face Dimensions Mating with CL150 Flanges

Valve Size, NPS	DIMENSIONS				Approximate Weight
	A	B	D	EØ	
	mm				Kg
1	184.0	83.0	199.0	108.0	10
1-1/2	222.0	97.0	220.0	127.0	17
2	254.0	107.0	228.0	152.4	20
3	298.0	121.0	330.0	190.5	39
4	350.0	176.0	340.0	220.0	42
Inches					Pounds
1	7.25	3.27	7.83	4.25	23
1-1/2	8.75	3.82	8.66	5.00	36
2	10.00	4.21	8.98	6.00	43
3	11.75	4.76	13.00	7.50	86
4	13.78	6.94	13.39	8.66	92

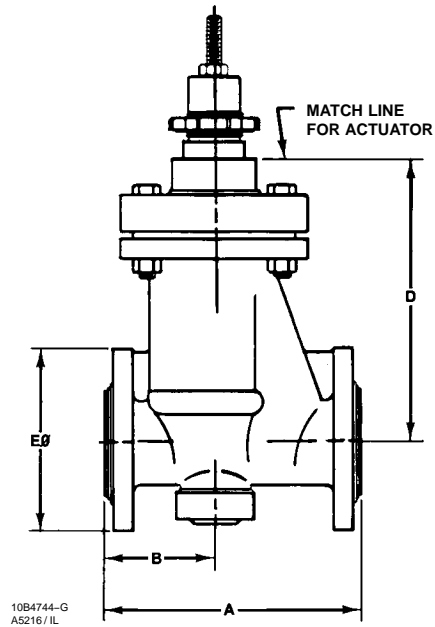

Figure 5. Dimensions and Weights (also see tables 4 and 5)

Table 5. ANSI/ISA CL300 Face-to-Face Dimensions Mating with CL300 Flanges

Valve Size, NPS	DIMENSIONS				Approximate Weight
	A	B	D	EØ	
	mm				Kg
1	197.0	90.0	199.0	123.8	11
1-1/2	235.0	101.0	220.0	156.0	18
2	267.0	115.0	228.0	165.0	20
Inches					Pounds
1	7.75	3.54	7.83	4.87	25
1-1/2	9.25	3.97	8.66	6.14	40
2	10.50	4.53	8.98	6.50	45

Note

Neither Emerson, Emerson Process Management, nor any of their affiliated entities assumes responsibility for the selection, use, or maintenance of any product. Responsibility for the selection, use, and maintenance of any product remains with the purchaser and end user.

Specifications

Valve Sizes

NPS ■ 1, ■ 1-1/2, ■ 2, ■ 3, ■ and 4

Face-To-Face and Flange Compatibility

VALVE SIZE, NPS	DUCTILE IRON			
	Raised-Face Flange			
	CL150		CL300	
	Face-To-Face			
	ASME ⁽¹⁾	DIN ⁽²⁾	ASME ⁽¹⁾	DIN ⁽²⁾
1	X	X	X	---
1-1/2	X	X	X	---
2	X	X	X	---
3	X	X	---	---
4	X	X	---	---

1. For ANSI/ISA face-to-face dimensions, see figure 5.
2. For DIN face-to-face dimensions, see figure 5.

Maximum Inlet Pressures and Temperatures⁽¹⁾

See table 2

Downstream/Outlet Pressure Ratings⁽¹⁾

See figure 3 for positive pressure service ratings
See figure 4 for vacuum service ratings

Application Limits

Liquid Service: For cavitating applications, contact your Emerson Process Management sales office

Gas Service: Velocity \leq 0.33 MACH

Shutoff Classification

Class VI per ANSI/FCI 70-2 and IEC 60534-4

Bellows Seal

Heavy-duty PTFE with SST support rings

Construction Materials

See table 3

Expected Life Cycle

Full Stroke: 500,000

Temperature Capabilities

Positive Pressure Service: -29 to 180°C (-20 to 360°F) (see figure 3).

Vacuum Service: -29 to 180°C (-20 to 360°F) (see figure 4)

Standard Flow Characteristic/Valve Plug Style

Equal percentage

Flow Direction

Up through the seat ring (see figure 2)

Flow Coefficients

See table 1, the section titled Coefficients in this bulletin, or Catalog 12 for coefficients of Fisher valves

Port Diameters and Maximum Valve Plug Travel

See table 1

Bonnet Style

Plain

Packing Arrangement

Braided PTFE rings

Yoke Boss and Stem Diameter

See table 1

Approximate Weight

See figure 5

Options

■ **Line-Flange gasket**, (stainless steel insert, compression gasket, and PTFE overlay) with thickness of 5.1 mm (0.20 inch) for NPS 1 through 2, and 7.1 mm (0.28 inch) for NPS 3 and 4 valves

■ **Tool** for removing and installing the seat ring

1. The pressure/temperature limits in this bulletin and any applicable standard or code limitation for the valve should not be exceeded.

Coefficients

Table 6. Fisher RSS, CL150 and 300, Equal Percentage, Flow Up through the Seat Ring

Equal Percentage														Equal Percentage Characteristic		
Valve Size, NPS	Port Diameter ⁽¹⁾		Maximum Travel		Flow Coefficient	Valve Opening—Percent of Total Travel										
	mm	Inches	mm	Inches		5	10	20	30	40	50	60	70	80	90	100
1	8	0.3125	15	0.591	C _v	0.050	0.073	0.117	0.156	0.215	0.390	0.546	0.715	0.934	1.28	1.91
					K _v	0.043	0.063	0.101	0.135	0.186	0.337	0.472	0.618	0.808	1.11	1.65
	15	0.5	15	0.591	C _v	0.139	0.182	0.262	0.427	0.559	0.684	0.842	1.08	1.48	2.23	3.57
					K _v	0.120	0.157	0.227	0.369	0.484	0.592	0.728	0.934	1.28	1.93	3.09
	20	0.75	15	0.591	C _v	0.443	0.585	0.917	1.28	1.77	2.43	3.25	4.52	5.61	7.21	8.41
					K _v	0.383	0.506	0.793	1.11	1.53	2.10	2.81	3.91	4.85	6.24	7.27
25	1	15	0.591	C _v	0.562	0.632	0.842	1.12	1.55	2.20	2.99	4.03	5.92	8.66	11.5	
				K _v	0.486	0.547	0.728	0.969	1.34	1.90	2.59	3.49	5.12	7.49	9.95	
1-1/2	25	1	19.1	0.75	C _v	0.599	0.660	0.905	1.24	1.70	2.30	3.06	4.25	6.45	9.66	13.4
					K _v	0.518	0.571	0.783	1.07	1.47	1.99	2.65	3.68	5.58	8.36	11.6
	40	1.5	19.1	0.75	C _v	1.54	1.76	2.24	3.08	4.44	6.54	9.66	13.8	18.4	23.7	28.6
					K _v	1.33	1.52	1.94	2.66	3.84	5.66	8.36	11.9	15.9	20.5	24.7
2	30	1.1875	19.1	0.75	C _v	0.508	0.582	0.763	1.05	1.56	2.32	3.17	4.31	6.03	8.92	13.3
					K _v	0.439	0.503	0.660	0.908	1.35	2.01	2.74	3.73	5.22	7.72	11.5
	50	2	19.1	0.75	C _v	2.14	2.50	3.79	5.58	9.20	12.5	16.2	21.0	28.1	36.6	44.3
					K _v	1.85	2.16	3.28	4.83	7.96	10.8	14.0	18.2	24.3	31.7	38.3
3	50	2	28.6	1.125	C _v	1.37	2.09	3.50	5.19	7.21	9.92	13.8	19.0	26.1	34.7	43.3
					K _v	1.19	1.81	3.03	4.49	6.24	8.58	11.9	16.4	22.6	30.0	37.5
	80	3.1875	28.6	1.125	C _v	3.44	4.93	8.23	12.5	18.0	25.5	35.9	49.6	66.2	81.5	94.1
					K _v	2.98	4.26	7.12	10.8	15.6	22.1	31.1	42.9	57.3	70.5	81.4
4	65	2.5	28.6	1.125	C _v	2.07	3.12	5.17	7.99	11.3	15.5	21.4	29.3	40.9	55.8	69.3
					K _v	1.79	2.70	4.47	6.91	9.77	13.4	18.5	25.3	35.4	48.3	59.9
	96	4	28.6	1.125	C _v	7.12	10.3	16.6	25.1	35.9	51.5	71.7	94.4	116	133	145
					K _v	6.16	8.91	14.4	21.7	31.1	44.5	62.0	81.7	100	115	125

1. Inch equivalents of these metric port diameters have been rounded to common fractional diameters. Actual diameter of the 15 millimeter port is 0.591 inches, of the 40 millimeter port is 1.575 inches, and of the 96 millimeter port is 3.780 inches.

Fisher and FIELDVUE are marks owned by one of the companies in the Emerson Process Management business division of Emerson Electric Co. Emerson Process Management, Emerson, and the Emerson logo are trademarks and service marks of Emerson Electric Co. All other marks are the property of their respective owners.

The contents of this publication are presented for informational purposes only, and while every effort has been made to ensure their accuracy, they are not to be construed as warranties or guarantees, express or implied, regarding the products or services described herein or their use or applicability. All sales are governed by our terms and conditions, which are available upon request. We reserve the right to modify or improve the designs or specifications of such products at any time without notice. Neither Emerson, Emerson Process Management, nor any of their affiliated entities assumes responsibility for the selection, use or maintenance of any product. Responsibility for proper selection, use, and maintenance of any product remains solely with the purchaser and end user.

Emerson Process Management

Marshalltown, Iowa 50158 USA
Sorocaba, 18087 Brazil
Chatham, Kent ME4 4QZ UK
Dubai, United Arab Emirates
Singapore 128461 Singapore

www.Fisher.com

