

Fisher® 8532 High-Performance Butterfly Valve

The Fisher 8532 high-performance butterfly valve (figure 1) provides outstanding performance under extreme pressure and temperature conditions. The 8532 valve maintains tight shutoff, is available in a fire-tested version, and can be specified for cryogenic applications.

The 8532 valve is available as either a flangeless, wafer-style design or as a single-flange (lugged) design. A splined drive shaft combines with a variety of spring-and-diaphragm or pneumatic piston actuators to make the 8532 a reliable,

high-performance butterfly valve for a variety of throttling and on-off applications in the various process industries.

The 8532 valve can be supplied with one of several dynamic seals (figure 5) that can be used in a variety of demanding applications. With the appropriate seal selection and materials of construction, the pressure-assisted seal provides excellent shutoff against the full CL150 or CL300 pressure ratings.

Unless otherwise noted, all NACE references are to NACE MR0175-2002.

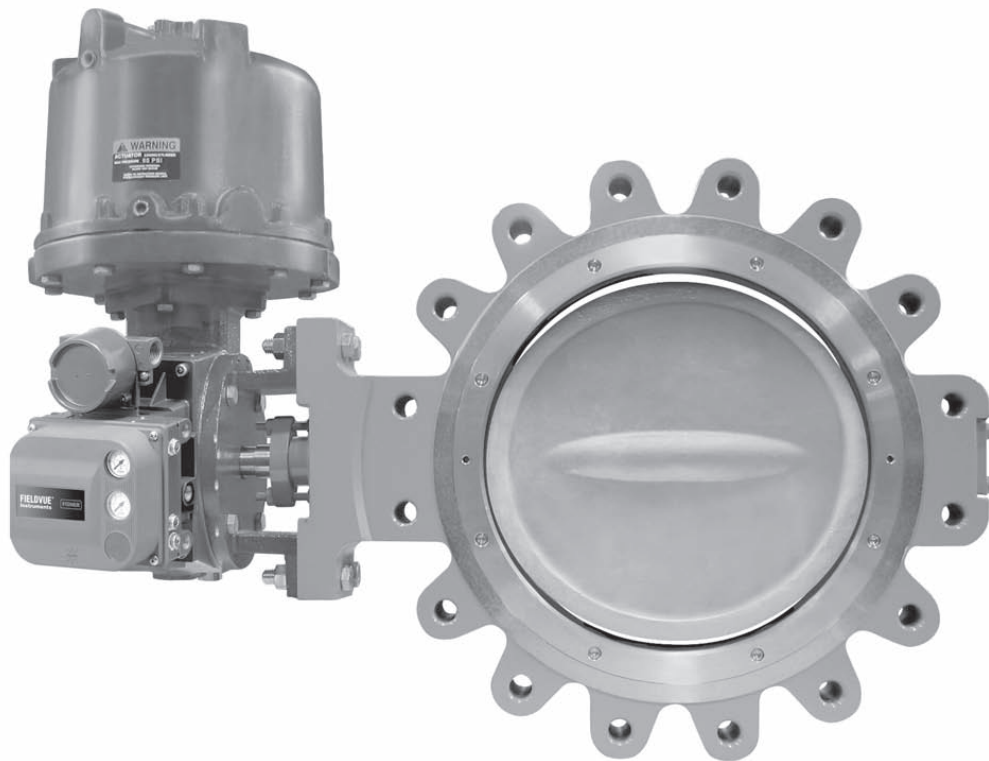

W9138-1

Figure 1. Fisher 8532 Valve



Specifications

Available Valve Configurations

■ Flangeless, wafer-style or ■ single-flange (lugged) control valve with a one-piece valve body, a two-component seal/backup O-ring, and a splined drive shaft

Valve Body Sizes

NPS ■ 14, ■ 16, ■ 18, ■ 20, and ■ 24

End Connection Style

■ Flangeless, wafer-style or ■ single flange valve body designed to fit between raised-face mating flanges per ASME B16.5 CL150 or CL300

Maximum Inlet Pressure/Temperature⁽¹⁾

Consistent with ■ CL150 and ■ CL300 pressure/temperature ratings per ASME B16.34. Also, see figures 3 and 4 for additional information

Available Seal Configurations

Standard Constructions

See figure 5 and table 2

Standard Construction Materials

Valve Body and Disc: ASTM grades of ■ carbon steel or ■ stainless steel

Disc Coating:

Hardcoating (also see table 2): ■ Standard when used with NOVEX seal, ■ Phoenix III seal, or ■ Cryogenic seal

Chromium Carbide: Standard when service temperature exceeds 538°C (1000°F)

Shaft: ASTM grade of ■ S17400 (17-4PH H1025 SST), ■ S17400 (17-4PH H1150M SST), or ■ S20910

Shaft Extension Lengths:

High Temperature ■ None required for temperatures less than 343°C (650°F),

■ 6 inches for temperatures from 343 to 538°C (650 to 1000°F), or ■ 12 inches for temperatures above 538°C (1000°F)

Cryogenic ■ 914mm (36 inches)

Seal Ring: ■ PTFE, ■ S31600 (316 SST), ■ S21800, ■ S31600/PTFE, ■ UHMWPE⁽⁴⁾, or ■ CTFE⁽⁵⁾.

Backup ring: ■ Nitrile, ■ Chloroprene, ■ PTFE, ■ Fluorocarbon—for a broad range of hydrocarbon and chemical process applications⁽¹⁾ or ■ EPR—for process applications including steam and water⁽¹⁾. A backup ring is not used with the NOVEX seal

Packing: ■ PTFE V-ring (standard packing), ■ Graphite (optional), or ■ ENVIRO-SEAL™ packing (optional)

Bearings: ■ PEEK⁽²⁾ (standard material), and ■ S31600, ■ PTFE Composition, or ■ CoCr-A (Alloy 6) (optional)

Valve Body Classification

Face-to-face dimensions are in compliance with MSS SP68 and API 609 standards; valve bodies are designed for installation between ASME B16.5 CL150 or CL300 raised-face flanges

Shutoff Classification. Per ANSI/FCI 70-2 and IEC 60534-4

Standard Soft Seal: Bidirectional bubble-tight shutoff

NOVEX Seal: Unidirectional shutoff 1% of Class IV (preferred flow direction only⁽³⁾), optional Class VI

Phoenix III Seal: Bidirectional bubble-tight

Phoenix III Seal for Fire Tested Applications: Class VI shutoff. Contact your Emerson Process Management sales office for more information.

Flow Characteristic

Modified equal percentage

Flow Coefficients

See table 1, the section titled Coefficients in this bulletin, and also Catalog 12.

Noise Levels

See Catalog 12 for sound pressure level prediction

Available Actuators

■ Spring-and-diaphragm, or ■ pneumatic piston

(continued)

Specifications (continued)

Disc Rotation

Clockwise to close

Valve Dimensions and Approximate Weights

See figures 8, 9, 10 and 11

ENVIRO-SEAL Packing

This optional ■ PTFE or ■ graphite packing system provides improved sealing, guiding, and transmission of loading force to control liquid and gas emissions. See Bulletin 59.3:041 ENVIRO-SEAL Packing Systems for Rotary Valves for more information.

1. The pressure/temperature limits in this bulletin (figures 3 and 4), and any application code or standard limitation, should not be exceeded.
 2. PEEK stands for poly-ether-ether-ketone.
 3. For optimum seal performance, the preferred valve orientation at shutoff is with the retaining ring downstream from the high pressure side of the valve.
 4. UHMWPE stands for ultra high molecular weight polyethylene.
 5. CTFE not recommended for fast cycling, less than 2 seconds. Contact your Emerson Process Management sales office for other seals available for fast cycling or tighter shutoff.

Features

- **Economical Tight Shutoff**—The pressure-assisted seal design provides tight shutoff against the full pressure rating of the specified valve.

- **Safety**—Shaft blowout protection is designed into the 8532 valve (figure 7). The anti-blowout gland fits securely over the valve shaft which has been turned down to form a circumferential shoulder that contacts the anti-blowout gland.

- **Excellent Flow Control**—With a modified equal percentage flow characteristic, the 8532 can be used for throttling applications through 90 degrees of disc rotation. Rangeability is 100 to 1.

- **Economically Designed for Minimal Deadband**—A splined end connection on the drive shaft allows lever clamping by most Fisher rotary actuators.

- **Application Versatility**—Standard construction materials and seal assemblies provide long life and outstanding performance in a broad range of liquid and gas applications.

- **Ease of Maintenance**—Interchangeability of all parts including shafts and discs simplifies service and reduces maintenance costs.

- **Improved Environmental Capabilities**—The optional ENVIRO-SEAL packing system is designed with very smooth stem surfaces and live-loading provides improved sealing, guiding, and loading force transmission. The ENVIRO-SEAL packing system can control emissions below the EPA (Environmental Protection Agency) limit of 100 ppm (parts per million).

- **Easy Installation**—The valve body self-centers on the line flange bolts as a fast, accurate means of centering the valve in the pipeline.

- **Reliable Flange Gasketing Surface**—Seal retainer screws are located so there is no interference with the sealing function of either flat sheet or spiral wound line flange gaskets.

Table 1. Flow Coefficients⁽¹⁾⁽³⁾

VALVE SIZE, NPS	MAX C _v ⁽²⁾ , VALVE 90° OPEN	
	CL150	CL300
14	6320	4550
16	8600	5630
18	11,050	8230
20	13,850	9530
24	21,500	12,510

1. To obtain the flow coefficient K_v in terms of cubic meters per hour at one kilogram force per square centimeter differential pressure across the valve, using the following multiplier: K_v = 0.856 C_v.
 2. Measured in gallons per minutes at 1 psi differential pressure across the valve.
 3. See the section titled Coefficients in this bulletin, and also Catalog 12 for a complete listing of flow coefficients.

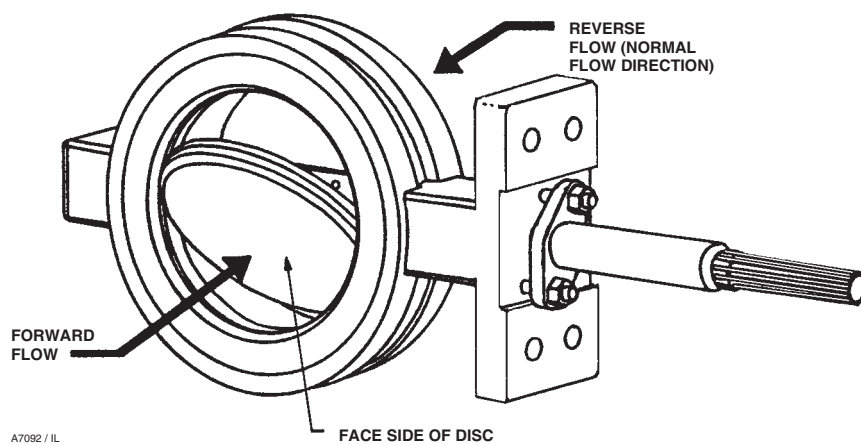

Figure 2. Flow Direction

Installation

Recommended installation for the 8532 valve is with the shaft horizontal in a normal-flow direction. Horizontal installation will enhance valve performance because process fluid flow will sweep entrained solids from valve surfaces. This sweeping action prevents particle buildup on seal surfaces. However, the valve may be installed in either the forward or reverse flow direction.

The standard soft seal offers bubble-tight, bidirectional shutoff. To meet the performance requirements of many of today's fire-tested requirements, a Phoenix III valve must be installed in the preferred valve orientation. Both the NOVEX and

cryogenic seals are uni-directional and should be installed with the shaft upstream of the seal.

Unique operating conditions may require a specific combination of actuator motion. To satisfy unique operating requirements, the valve and actuator can be assembled in eight ways, providing for actuator motion and open disc position. For assistance in selecting the appropriate combination of actuator action and open valve position, consult your Emerson Process Management sales office.

Dimensions and weights for wafer-style and single-flange valves are shown in figures 8, 9, 10 and 11.

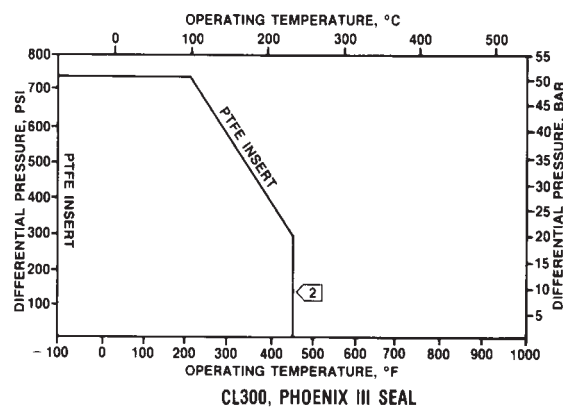
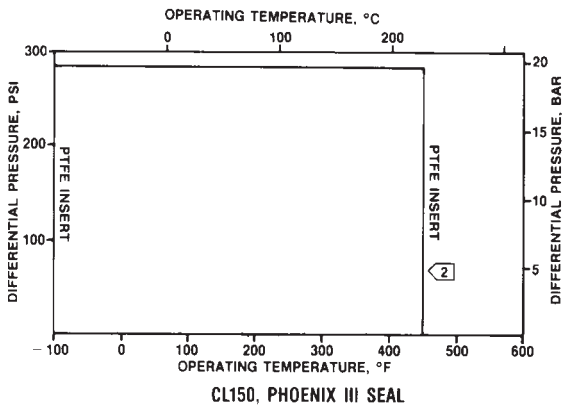
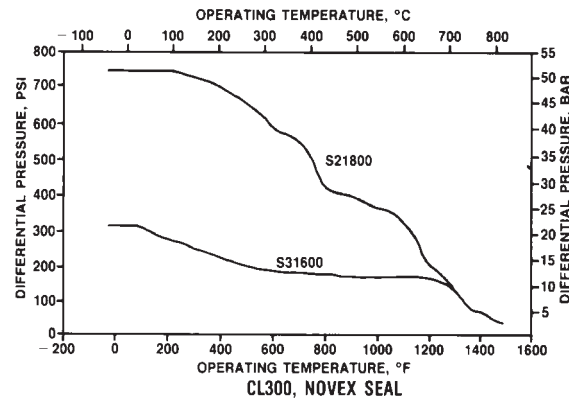
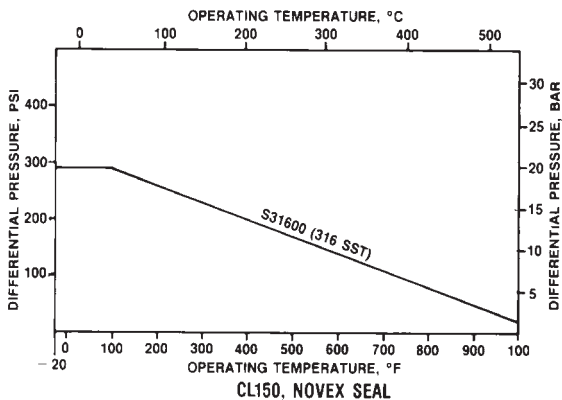
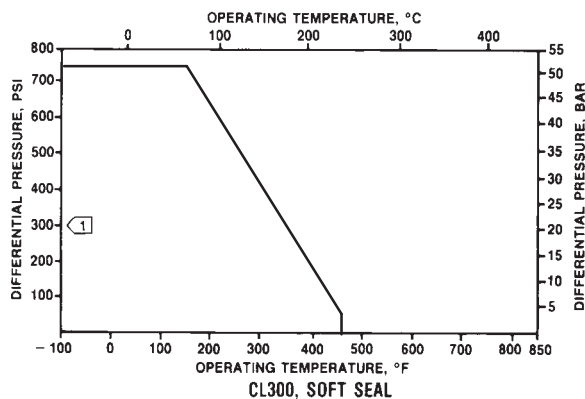
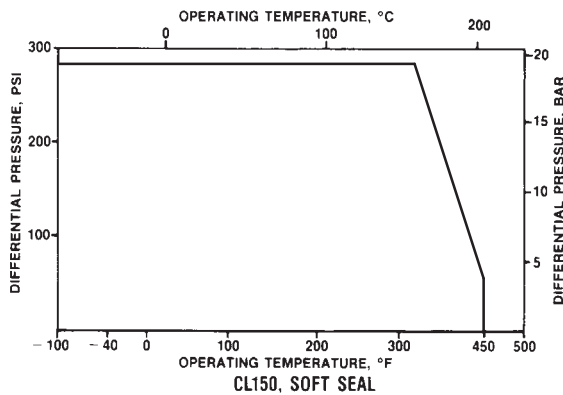

NOTE:

1 BECAUSE OF POTENTIAL EROSIIVE EFFECTS AND PREMATURE SEAL FAILURE THAN CAN OCCUR, THROTTLING PTFE SEALS AT DIFFERENTIAL PRESSURES GREATER THAN 300 PSID AT DISK ANGLES LESS THAN 20° OPEN IS NOT RECOMMENDED.

C0759-1 / IL

NOTE:

2 TEMPERATURE LIMITATIONS DO NOT ACCOUNT FOR THE ADDITIONAL LIMITATIONS IMPOSED BY THE BACKUP O-RING USED WITH THIS SEAL. TO DETERMINE THE EFFECTIVE TEMPERATURE LIMITATION OF THE APPROPRIATE SEAL/BACKUP O-RING COMBINATION, REFER TO TABLE 1.

Figure 3. Maximum Pressure/Temperature Ratings for Soft Seal, NOVEX Seal and Phoenix III Seal, CL150 and CL300

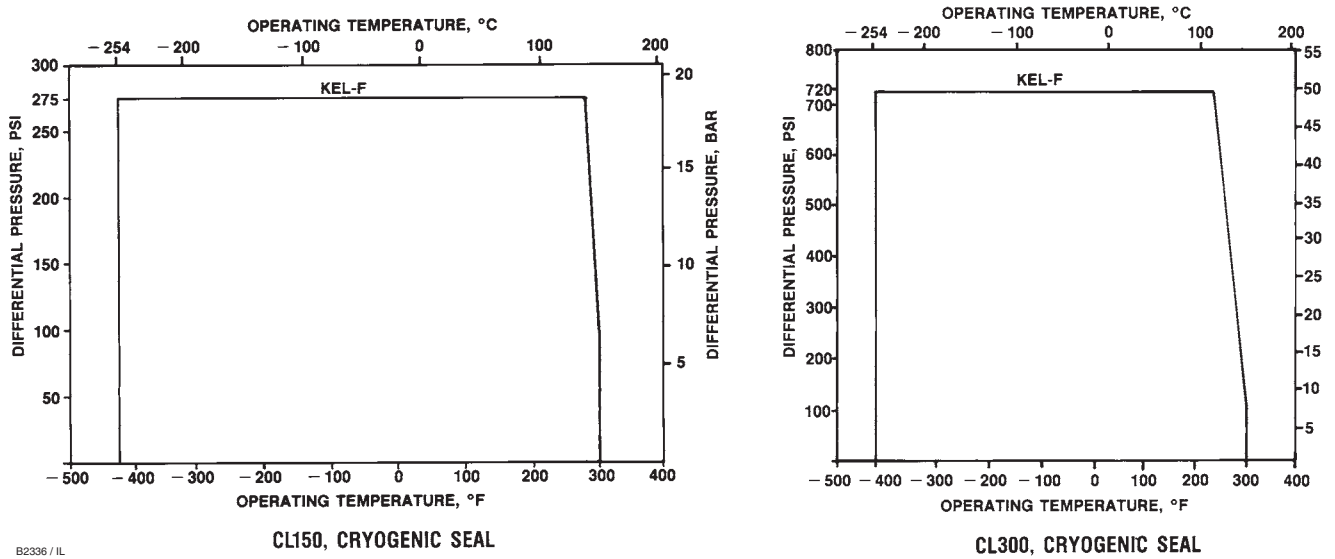

Figure 4. Maximum Pressure/Temperature Ratings for Cryogenic Seal, CL150 and CL300

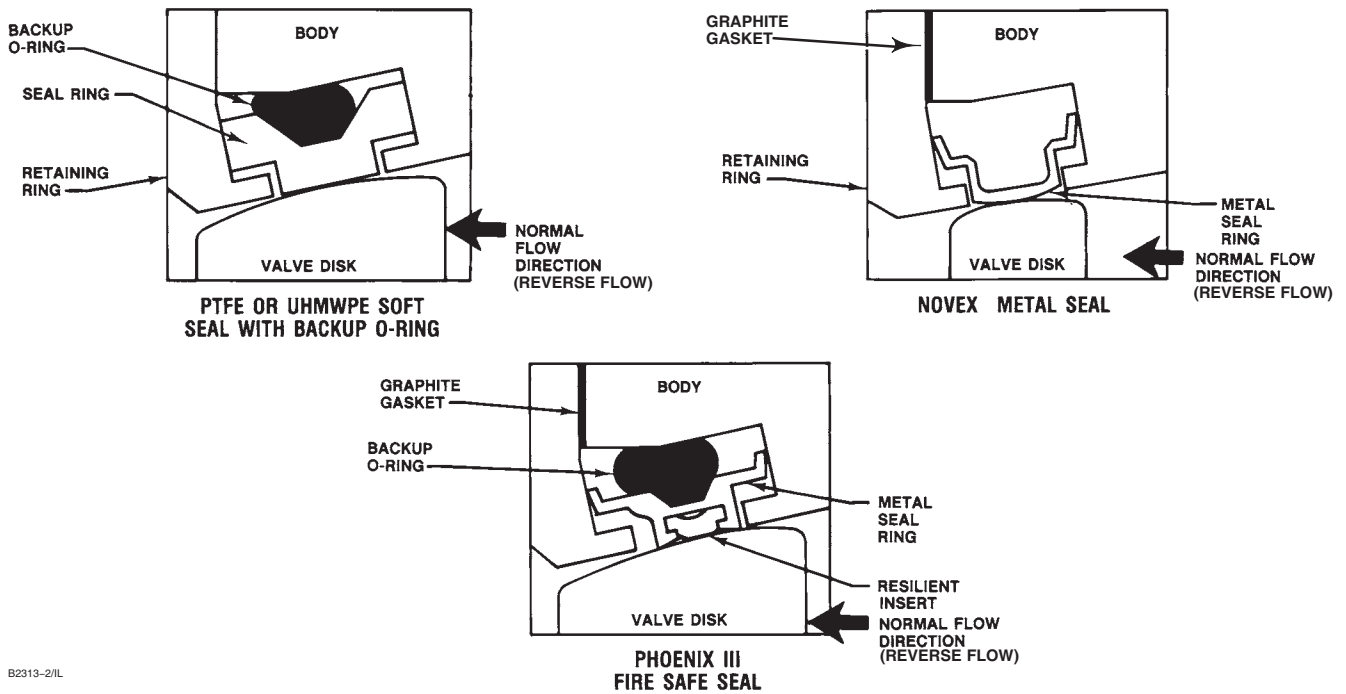

Figure 5. Available Seal Configurations

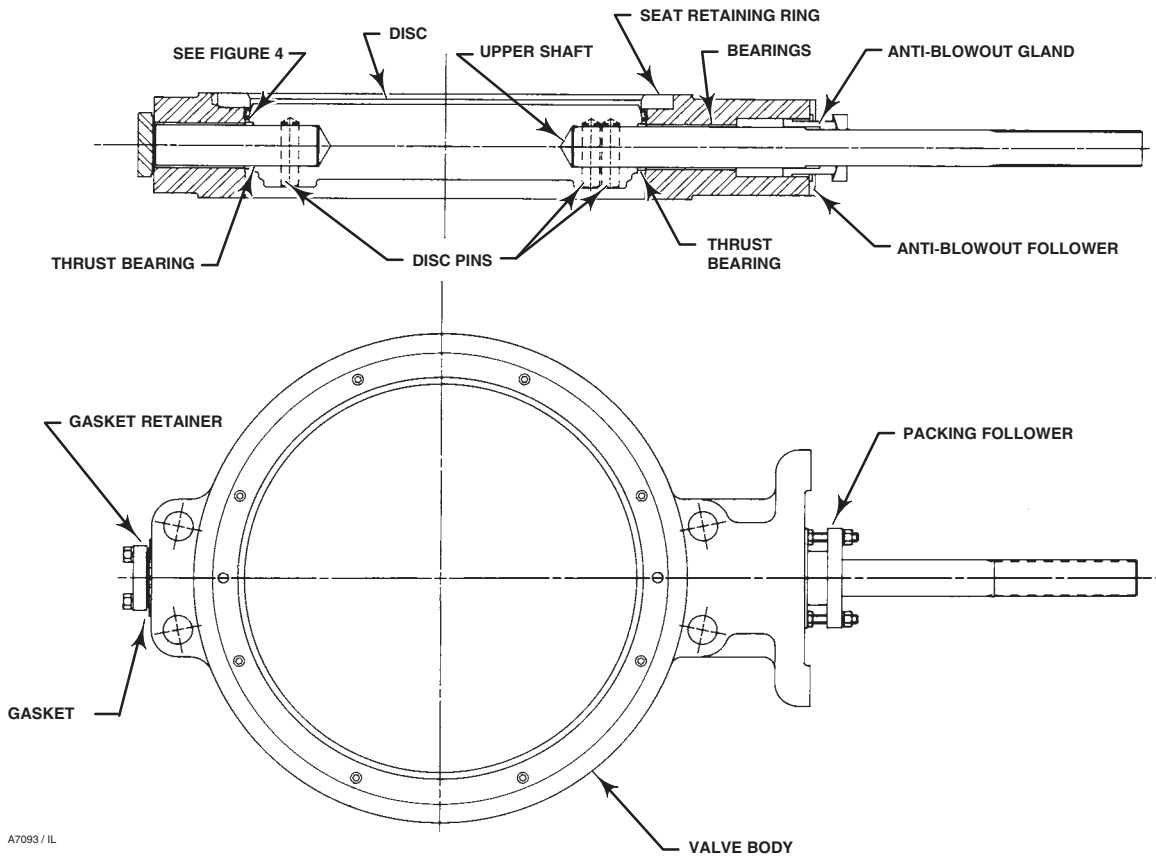

Figure 6. Typical Valve Assembly

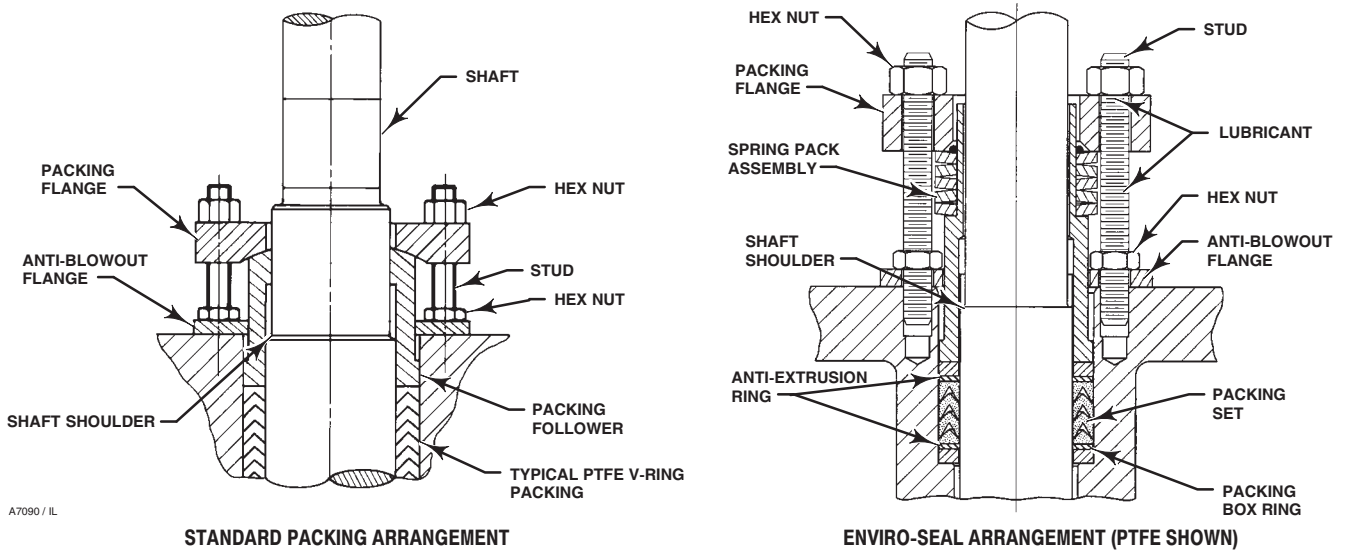

Figure 7. Blowout Protection

Table 2. Material Temperature Ratings

COMPONENT AND MATERIAL OF CONSTRUCTION ⁽¹⁾		TEMPERATURE RANGE	
		°C	°F
Valve Body⁽²⁾ Carbon Steel (WCC or SA 516-70) ⁽⁷⁾ CF8M (316 SST) CL150 and CL300 CF8M ⁽³⁾ FMS 20B16 a Fisher material standard (0.04% min carbon) CL300		-29 to 427 -198 to 538 over 538 to 816	-20 to 800 -325 to 1000 over 1000 to 1500
Disc WCC carbon steel CF8M (316 SST) CF8M ⁽³⁾ FMS 20B16 a Fisher material standard (0.04% min carbon) CL300		-29 to 427 -198 to 538 over 538 to 816	-20 to 800 -325 to 1000 over 1000 to 1500
Disc Coating Chromium Carbide Chrome Plating Electroless Nickel Coating (ENC)		-198 to 916 -254 to 343 -254 to 538	-325 to 1500 -425 to 650 -425 to 1000
Shaft S20910 S17400 (17-4 pH 1025) S17400 (17-4 pH H1150M) N07718 N07750		-198 to 538 -73 to 427 -196 to 427 -254 to 704 over 593 to 816	-325 to 1000 -100 to 800 -320 to 800 -425 to 1300 over 1100 to 1500
Bearings⁽⁶⁾ PEEK (standard) S31600 ⁽⁴⁾ R30006 (Alloy 6) Bronze		-73 to 260 -198 to 816 -198 to 816 -254 to 302	-100 to 500 -325 to 1500 -325 to 1500 -425 to 575
Packing PTFE Packing and PTFE ENVIRO-SEAL Packing Graphite packing Graphite packing with oxidizing media Graphite ENVIRO-SEAL Packing		-148 to 232 -198 to 916 -198 to 538 -148 to 315	-325 to 450 -325 to 1500 -325 to 1000 -325 to 600
Seal Ring and Backup Ring	PTFE Seal Ring Nitrile Backup O-Ring Chloroprene Backup O-Ring EPR Backup O-Ring Fluorocarbon Backup O-Ring PTFE Backup O-Ring	-29 to 93 -43 to 149 -54 to 182 -29 to 204 -73 to 204	-20 to 200 -45 to 300 -65 to 360 -20 to 400 -100 to 400
	UHMWPE⁽⁵⁾ Seal Ring (CL150 Only) Nitrile Backup O-Ring Chloroprene Backup O-Ring EPR Backup O-Ring Fluorocarbon Backup O-Ring PTFE Backup O-Ring	-29 to 93 -43 to 93 -54 to 93 -29 to 93 -73 to 93	-20 to 200 -45 to 200 -65 to 200 -20 to 200 -40 to 200
	Phoenix III and/or Fire Tested Construction S31600 and PTFE Seal Ring with Nitrile Backup O-Ring Chloroprene Backup O-Ring EPR Backup O-Ring Fluorocarbon Backup O-Ring	-40 to 149 -54 to 149 -62 to 204 -40 to 232	-40 to 300 -65 to 300 -80 to 400 -100 to 200
Seal Ring	NOVEX S31600 Seal ⁽⁴⁾ Ring (CL150) NOVEX S31600 Seal ⁽⁴⁾ Ring (CL300) NOVEX S21800 Seal ⁽⁴⁾ Ring (CL300)	-29 to 538 -29 to 816 -29 to 816	-20 to 1000 -20 to 1500 -40 to 1500
	Cryogenic Seal Ring	Contact your Emerson Process Management sales office	

1. NACE trim constructions are available; consult your Emerson Process Management sales office.
2. Special gasket retainer bolts are required for over 482°C (900°F)
3. Special retaining ring screws for single flange valves over 538°C (1000°F)
4. For a complete material description, contact your Emerson Process Management sales office.
5. UHMWPE stands for ultra high molecular weight polyethylene.
6. Special thrust bearings are required for high temp. applications over 343°C (650°F) (with 6- and 12-inch shaft extensions). Constructions with carbon steel valves and SST discs may require special thrust bearings at temperatures less than 343°C (650°F).
7. Cast or wrought /plate grades used interchangeably, depending upon availability – unless requested by customer.

Product Bulletin

51.6:8532
September 2009

8532 Valve

Table 3. Dimensions and Weights, Wafer Style Valves, CL150

Valve Size, NPS	A ⁽¹⁾	D	G	K	M ⁽²⁾	R	S (Shaft Dia at Yoke Bearings)	T	U	W	Y	Approx Weight
mm												kg
14	91.9	208	295	327	331	422	31.8	235	46.0	17.5	---	72
16	102	208	318	371	375	465	31.8	235	46.0	17.5	28.6 4 holes	94
18	114	356	349	400	419	529	39.6	273	50.8	20.1	31.8 4 holes	139
20	127	356	381	432	464	584	44.5	273	50.8	20.1	31.8 4 holes	167
24	154	356	438	492	581	692	57.2	337	76.2	23.9	34.9 4 holes	255
Inches												Pounds
14	3.62	8.19	11.62	12.88	13.04	16.62	1-1/4	9.25	1.81	0.69	---	158
16	4.00	8.19	12.50	14.62	14.77	18.31	1-1/4	9.25	1.81	0.69	1-1/8 4 holes	207
18	4.50	14	13.75	15.75	16.49	20.81	1-9/16	10.75	2.00	0.81	1-1/4 4 holes	307
20	5.00	14	15.00	17.00	18.27	23.00	1-3/4	10.75	2.00	0.81	1-1/4 4 holes	368
24	6.06	14	17.25	19.38	22.87	27.25	2-1/4	13.25	3.00	0.94	1-3/8 4 holes	563

1. Face-to-face dimensions are in compliance with MSS SP68 and API 609 specifications.
2. M is the minimum pipe or flange I.D. required for disc swing clearance.

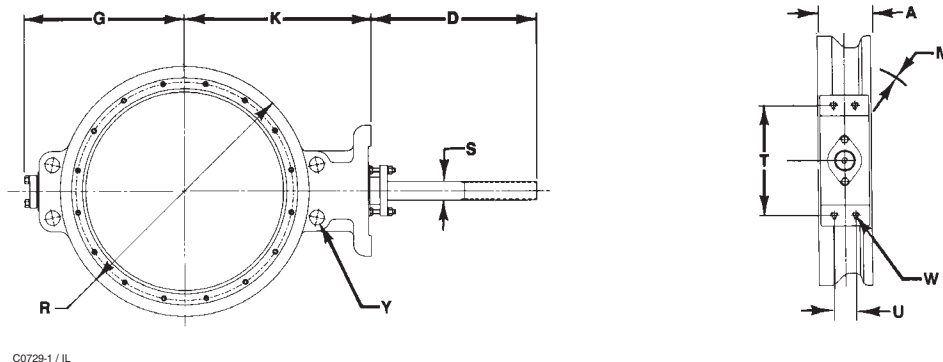

Figure 8. Dimensions and Weights, Wafer Style Valves, CL150 (also see table 3)

8532 Valve

Table 4. Dimensions and Weights, Single Flange Valves, CL150

Valve Size, NPS	A ⁽¹⁾	D	G	K	M ⁽²⁾	R	S (Shaft Dia at Yoke Bearings)	T	U	W	Y	Approx Weight
mm												kg
14	91.9	208	295	327	331	531	31.8	235	46.0	14.2	---	95
16	102	208	318	371	375	607	31.8	235	46.0	14.2	---	138
18	114	356	349	400	419	645	39.7	273	50.8	20.1	---	178
20	127	356	381	432	464	696	44.5	273	50.8	20.1	---	224
24	154	356	438	492	581	822	57.2	337	76.2	23.9	---	315
Inches												Pounds
14	3.62	8.19	11.62	12.88	13.04	20.88	1-1/4	9.25	1.81	0.56	1-8 12 Holes	209
16	4.00	8.19	12.50	14.62	14.77	23.88	1-1/4	9.25	1.81	0.56	1-8 16 Holes	304
18	4.50	14	13.75	15.75	16.49	25.38	1-9/16	10.75	2.00	0.81	1-1/8-8 16 Holes	393
20	5.00	14	15.00	17.00	18.27	27.38	1-3/4	10.75	2.00	0.81	1-1/8-8 20 Holes	493
24	6.06	14	17.25	19.38	22.87	32.38	2-1/4	13.25	3.00	0.94	1-1/4-8 20 Holes	773

1. Face-to-face dimensions are in compliance with MSS SP68 and API 609 specifications.
2. M is the minimum pipe or flange I.D. required for disc swing clearance.

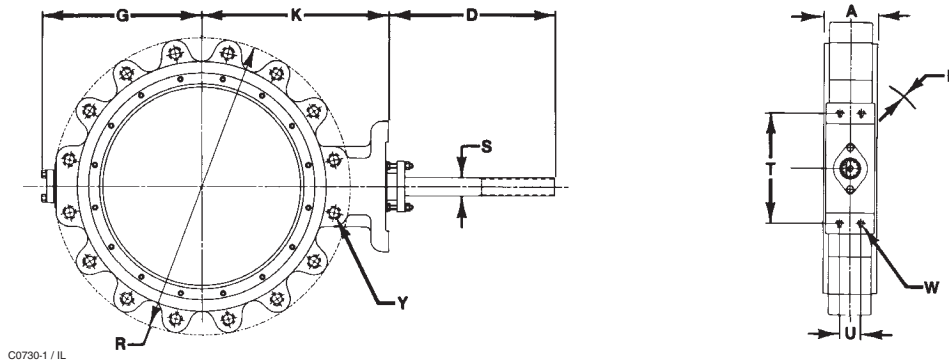

Figure 9. Dimensions and Weights, Single Flange Valves, CL150 (also see table 4).

Product Bulletin

51.6:8532
September 2009

8532 Valve

Table 5. Dimensions and Weights, Wafer Style Valves, CL300

Valve Size, NPS	A ⁽¹⁾	D	G	K	M ⁽²⁾	R	S (Shaft Dia at Yoke Bearings)	T	U	W	Y	Approx Weight
mm												kg
14	117	356	319	364	304	437	44.5	273	50.8	20.6	---	121
16	133	356	353	397	346	498	44.5	273	50.8	20.6	---	183
18	149	356	384	419	389	556	57.2	337	76.2	23.9	---	227
20	159	265	416	483	442	605	76	337	76.2	23.9	---	364
24	181	265	483	546	523	716	89	337	76.2	23.9	---	469
Inches												Pounds
14	4.62	14	12.56	14.31	12	17.19	1-3/4	10.75	2	0.81	1-1/8-8 4 Holes	266
16	5.25	14	13.88	15.62	13.6	19.62	1-3/4	10.75	2	0.81	1-1/4-8 4 Holes	403
18	5.88	14	15.12	16.50	15.3	21.88	2-1/4	13.25	3	0.94	1-1/4-8 4 Holes	500
20	6.25	10-7/16	16.38	19.00	17.4	23.81	3	13.25	3	0.94	1-1/4-8 4 Holes	802
24	7.12	10-7/16	19.00	21.50	20.6	28.19	3-1/2	13.25	3	0.94	1-1/2-8 4 Holes	1035

1. Face-to-face dimensions are in compliance with MSS SP68 and API 609 specifications.
2. M is the minimum pipe or flange I.D. required for disc swing clearance.

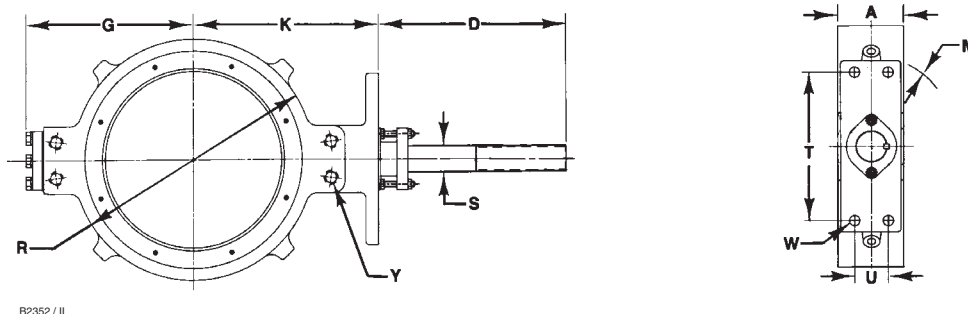
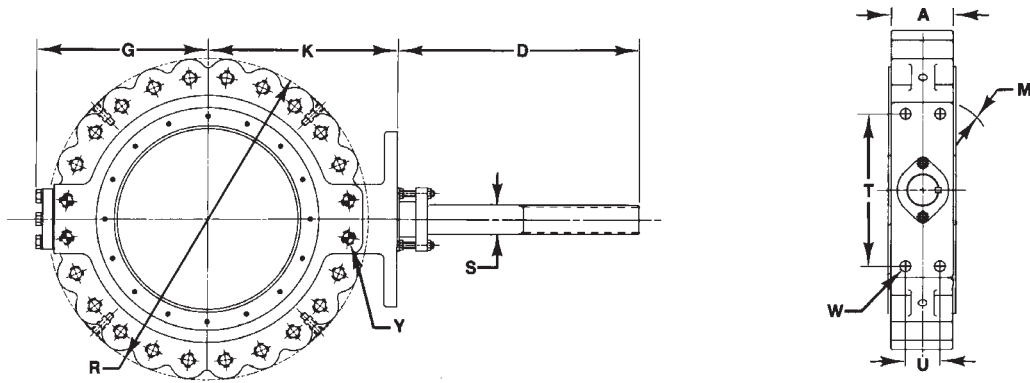

Figure 10. Dimensions and Weights, Wafer Style Valves, CL300 (also see table 5).

Table 6. Dimensions and Weights, Single Flange Valves, CL300

Valve Size, NPS	A ⁽¹⁾	D	G	K	M ⁽²⁾	R	S (Shaft Dia at Yoke Bearings)	T	U	W	Y	Approx Weight
mm												kg
14	117	356	319	364	304	594	44.5	273	50.8	20.6	---	227
16	133	356	353	397	346	657	44.5	273	50.8	20.6	---	294
18	149	356	384	419	389	721	57.2	337	76.2	23.9	---	402
20	159	265	416	483	442	784	76	337	76.2	23.9	---	544
24	181	265	483	546	523	924	89	337	76.2	23.9	---	821
Inches												Pounds
14	4.62	14	12.56	14.31	12.0	23.38	1-3/4	10.75	2	0.81	1-1/8-8 16 Holes	500
16	5.25	14	13.88	15.62	13.6	25.88	1-3/4	10.75	2	0.81	1-1/4-8 20 Holes	649
18	5.88	14	15.12	16.50	15.3	28.38	2-1/4	13.25	3	0.94	1-1/4-8 24 Holes	886
20	6.25	10-7/16	16.38	19.00	17.4	30.88	3	13.25	3	0.94	1-1/4-8 24 Holes	1200
24	7.12	10-7/16	19.00	21.50	20.	36.38	3-1/2	13.25	3	0.94	1-1/2-8 24 Holes	1810

1. Face-to-face dimensions are in compliance with MSS SP68 and API 609 specifications.
 2. M is the minimum pipe or flange I.D. required for disc swing clearance.



B2353 / IL

Figure 11. Dimensions and Weights, Single Flange Valves, CL300 (also see table 6)

Coefficients

Table 7. Fisher 8532, CL150, Reverse Flow

Coefficients	Valve Size, NPS	Valve Rotation, Degrees								
		10	20	30	40	50	60	70	80	90
C _v	14	95	316	695	1200	1900	2840	3980	5120	6320
K _v		82.2	273	601	1038	1643	2457	3443	4429	5467
F _d		0.090	0.17	0.26	0.34	0.42	0.49	0.57	0.64	0.70
F _L		0.77	0.79	0.81	0.81	0.78	0.73	0.68	0.60	0.52
X _T		0.50	0.53	0.55	0.55	0.51	0.45	0.39	0.30	0.23
C _v	16	129	430	946	1640	2580	3870	5420	6970	8600
K _v		112	372	818	1419	2232	3348	4688	6029	7439
F _d		0.090	0.17	0.26	0.34	0.42	0.49	0.57	0.64	0.70
F _L		0.77	0.79	0.81	0.81	0.78	0.73	0.68	0.60	0.52
X _T		0.50	0.53	0.55	0.51	0.51	0.45	0.39	0.30	0.23
C _v	18	166	553	1220	2100	3320	4970	6960	8950	11050
K _v		144	478	1055	1817	2872	4299	6020	7742	9558
F _d		0.090	0.17	0.26	0.34	0.42	0.49	0.57	0.64	0.70
F _L		0.77	0.79	0.81	0.81	0.78	0.73	0.68	0.60	0.52
X _T		0.50	0.53	0.55	0.55	0.51	0.45	0.39	0.30	0.23
C _v	20	208	692	1520	2630	4160	6230	8730	11220	13850
K _v		180	599	1315	2275	3598	5389	7551	9705	11980
F _d		0.090	0.17	0.26	0.34	0.42	0.49	0.57	0.64	0.70
F _L		0.77	0.79	0.81	0.81	0.78	0.73	0.68	0.60	0.52
X _T		0.50	0.53	0.55	0.55	0.51	0.45	0.39	0.30	0.23
C _v	24	322	1080	2370	4080	6450	9670	13540	17410	21500
K _v		277	934	2050	3529	5579	8365	11712	15060	18598
F _d		0.090	0.17	0.26	0.34	0.42	0.49	0.57	0.64	0.70
F _L		0.77	0.79	0.81	0.81	0.78	0.73	0.68	0.60	0.52
X _T		0.50	0.53	0.55	0.55	0.51	0.45	0.39	0.30	0.23

Table 8. Fisher 8532, CL300, Reverse Flow

Coefficients	Valve Size, NPS	Valve Rotation, Degrees								
		10	20	30	40	50	60	70	80	90
C _v	14	136	341	704	1200	1860	2680	3450	4050	4550
K _v		118	295	609	1038	1609	2318	2984	3503	3936
F _d		0.090	0.17	0.26	0.34	0.42	0.49	0.57	0.64	0.70
F _L		0.78	0.81	0.81	0.79	0.75	0.69	0.62	0.56	0.52
X _T		0.51	0.55	0.55	0.53	0.47	0.40	0.33	0.26	0.23
C _v	16	169	422	873	1490	2310	3320	4280	5010	5630
K _v		146	365	755	1289	1998	2872	3702	4334	4870
F _d		0.090	0.17	0.26	0.34	0.42	0.49	0.57	0.64	0.70
F _L		0.78	0.81	0.81	0.79	0.75	0.69	0.62	0.56	0.52
X _T		0.51	0.55	0.55	0.53	0.47	0.40	0.33	0.26	0.23
C _v	18	247	617	1280	2180	3370	4860	6260	7330	8230
K _v		214	534	1107	1886	2915	4204	5415	6340	7119
F _d		0.090	0.17	0.26	0.34	0.42	0.49	0.57	0.64	0.70
F _L		0.78	0.81	0.81	0.79	0.75	0.69	0.62	0.56	0.52
X _T		0.51	0.55	0.55	0.53	0.47	0.40	0.33	0.26	0.23
C _v	20	286	714	1480	2520	3910	5620	7240	8480	9530
K _v		247	618	1280	2180	3382	4861	6263	7335	8243
F _d		0.090	0.17	0.26	0.34	0.42	0.49	0.57	0.64	0.70
F _L		0.78	0.81	0.81	0.79	0.75	0.69	0.62	0.56	0.52
X _T		0.51	0.55	0.55	0.53	0.47	0.40	0.33	0.26	0.23
C _v	24	375	938	1940	3320	5130	7380	9510	11140	12510
K _v		324	811	1678	2872	4437	6384	8226	9636	10821
F _d		0.090	0.17	0.26	0.34	0.42	0.49	0.57	0.64	0.70
F _L		0.78	0.81	0.81	0.79	0.75	0.69	0.62	0.56	0.52
X _T		0.51	0.55	0.55	0.53	0.47	0.40	0.33	0.26	0.23

Note

Neither Emerson, Emerson Process Management, nor any of their affiliated entities assumes responsibility for the selection, use, or maintenance of any product. Responsibility for the selection, use and maintenance of any product remains with the purchaser and end user.

Fisher and ENVIRO-SEAL are marks owned by one of the companies in the Emerson Process Management business division of Emerson Electric Co. Emerson Process Management, Emerson, and the Emerson logo are trademarks and service marks of Emerson Electric Co. All other marks are the property of their respective owners.

The contents of this publication are presented for informational purposes only, and while every effort has been made to ensure their accuracy, they are not to be construed as warranties or guarantees, express or implied, regarding the products or services described herein or their use or applicability. All sales are governed by our terms and conditions, which are available upon request. We reserve the right to modify or improve the designs or specifications of such products at any time without notice. Neither Emerson, Emerson Process Management, nor any of their affiliated entities assumes responsibility for the selection, use or maintenance of any product. Responsibility for proper selection, use, and maintenance of any product remains solely with the purchaser and end user.

Emerson Process Management

Marshalltown, Iowa 50158 USA

Sorocaba, 18087 Brazil

Chatham, Kent ME4 4QZ UK

Dubai, United Arab Emirates

Singapore 128461 Singapore

www.Fisher.com

